



ALUKOMEN

katalog okovja fittings catalogue



ALUKOMEN

the company

podjetje

Alukomen. An important story.

The company **Alukomen** was founded in 1955 in Komen, a town in the Karst region. With time, the small company grew, developed and specialised.

A gradual expansion led to the founding of the company *Alukomen Montal*, dealing with production of outer glass facades, ALU and PVC windows, doors, porches, winter gardens and other builder's joinery, and the company *Alukomen Oprema*, manufacturing mountings for glass doors and walls, floorspring boxes for sliding doors, wing doors, warehouse and archive equipment and museum equipment (*glass cases, presentation panels, etc.*).

More than 50 years of constant progress brought **Alukomen** enviable results and references on domestic as well as on foreign markets.

Today *Alukomen Montal* and *Alukomen Oprema* represent the trademark **Alukomen** on world markets, distinguished by tested professionalization of technical and business team, distinctive quality of products present on the market, and a long term guarantee for all offered solutions.

Alukomen. The development continues.

Alukomen. Pomembna zgodba.

Podjetje **Alukomen** je bilo ustanovljeno leta 1955 v Komnu na Krasu. Sčasoma je majhno podjetje zrastlo, se razvijalo in specializiralo.

Postopno povečanje je vodilo do ustanovitve podjetij *Alukomen Montal*, ki se ukvarja s proizvodnjo zunanjih steklenih fasad, ALU in PVC oken, vrat, verand, zimskih vrtov in drugega stavbnega pohištva ter *Alukomen Oprema*, ki proizvaja okovje za steklena vrata in stene, vgradne kasete za drsna vrata, notranja vrata, skladiščno in arhivsko opremo ter opremo za muzeje (*vitrine, podesti, prezentacijski panoji...*).

Več kot 50 let nenehnega napredka je pripeljalo **Alukomen** do zavidljivih rezultatov in referenc tako na domačih kot tujih trgih.

Alukomen Montal in *Alukomen Oprema* se danes na svetovnih trgih predstavljata pod skupno blagovno znamko **Alukomen**, ki jo odlikujejo preizkušena profesionalnost tehnične in poslovne ekipe podjetja, značilna kakovost izdelkov, ki so prisotni na trgu, ter dolgoročno jamstvo za vse ponujene rešitve.

Alukomen. Razvoj se nadaljuje.

Alukomen. Ena resničnost, več predlogov.

Z leti se je podjetje Alukomen razširilo, proizvodnja pa je postala bolj raznolika. Danes vam nudimo pestro izbiro specifičnih rešitev.

vgradne kasete
za drsna vrata
za kvaliteto bivalnih prostorov

okovje za steklena
vrata in stene
dizajn po meri

muzejska
oprema
po predpisih stroke



sliding door
frames
for the quality of living spaces

mountings for glass
doors and walls
custom design

museum
equipment
according to regulations of the
profession

Alukomen. One reality, more suggestions.

Company Alukomen expanded and diversified its production with years. Today, we can offer a wide variety of specific solutions.

stavbno
pohištvo
avtorska arhitektura

strukturne
fasade
karakter arhitekture in urbanizma

vrata
univerzalnost lepote



builder's
carpentry
copyright architecture

structural
facades
the character of architecture
and urbanism

doors
the universality of beauty





kazalo_list of contents

stil_style	08
robustnost_robustness	10
kakovost_quality	12
tipologije vrat insten_door and wall typologies.....	14
simboli_symbols	15
linija Mollis_Mollis collection.....	17
linija Durus_Durus collection	45
drsni sistemi_sliding systems.....	79
sklopni sistemi_folding doors	95
talna zapirala_floorsprings.....	101
opcije in didatki_optionals	105



stil_style

Alukomen je stil.

Alukomen si že od samega začetka prizadeva slediti oblikovalskim trendom.

S tehnološko dovršenimi in inovativnimi proizvodnimi procesi oblikujemo aluminij v uporabno lepoto.

Izdelki skupine **Alukomen** so viden dokaz, da obstaja ljubezen za obliko, trud za inovacijo, strast za dizajn in iskanje popolnosti. Ena od linij vratnega okovja Mollis je moderen, ergonomski produkt za steklena vrata medtem ko linija Durus ostaja klasična, robustna s poudarkom na ravnih linijah.

Alukomen for Design. Alukomen za vsakega nekaj.

Alukomen means style.

Already from the beginning, **Alukomen** strives to follow designer trends. With technologically perfected and innovative manufacturing processes aluminium is converted to useful beauty.

Products of the **Alukomen** group are the visible evidence of love behind the form, of effort for innovations, passion for design and search for perfection. One of the collections of door fittings Mollis is a modern and ergonomic product intended for glass doors, while the Durus collection remains classic and robust with accentuation on straight lines.

Alukomen for Design. Alukomen – something for everyone.









robustnost_robustness

Alukomen je trdnost.

Trden. Pridevnik, ki najbolj primerno opisuje **Alukomen**.

Trdna je oprema, ki se proizvaja: obstojna, robustna, izdelana tako, da traja.

Trdne so vezi, ki jih podjetje vzpostavlja s svojimi sogovorniki in s strankami: zaupanje, pomoč in fleksibilnost odlikujejo celotno verigo ustvarjalne vrednosti, na področju katere deluje podjetje.

Konkretnost Alukomen pred očmi vseh.

Alukomen means firmness.

Firm. This adjective offers the best description of **Alukomen**. The equipment in production is: stable, robust and manufactured to last. Bonds formed between the company and its partners in dialogue as well as its clients are stable: trust, help and flexibility distinguish the whole chain of creative value in the operating area of the company.

The competitiveness of Alukomen in the plain sight of everyone.

kakovost

quality

Durus & Mollis

Prvotna linija DURUS okovja je bila in je še vedno za Alukomen pomembna zaradi svoje kakovosti in oblike. Trendi v arhitekturi in oblikovanju se spreminjajo, zato smo leta 2006 pod svojo lastno znamko izdelkov MOLLIS in v sodelovanju s priznanim arhitektom Rokom Kuharjem oblikovali popolnoma novo linijo rešitev z dovršeno obliko steklenih vrat in sten. Izdelki estetsko dopolnjujejo še tako zahtevno notranjo opremo kot tudi poslovne in stanovanjske prostore. Značilnosti linije MOLLIS so moderna, brezčasna preprostost, gola arhitektura, prepletanje tradicionalne obrti s sodobnim pristopom industrijskega oblikovanja in patent tehnološke izdelave in designa.

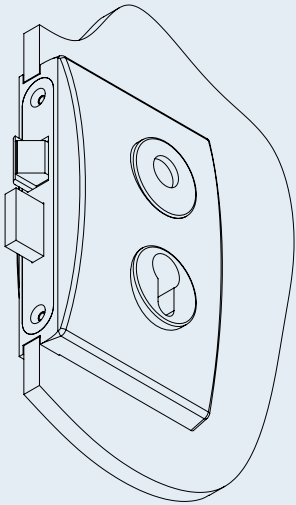

Durus & Mollis

The original collection of DURUS fittings was and still is very important to Alukomen because its quality and form. Because trends in architecture and design change, we designed a completely new collection of solutions of glass doors and walls with unblemished form under our own trademark MOLLIS and in cooperation with acknowledged architect Rok Kuhar. The products aesthetically supplement even the most demanding interior equipment as well as business and accommodation spaces. The characteristics of MOLLIS collection are modern, timeless simplicity, sheer architecture, intertwining of traditional craft with the modern approach of industrial design, the patent of technological manufacture and design.

Materiali in embalaža

Uporabljamo najboljši material - aluminij, ki ima raznoliko obdelovalno površino. Izdelke skupine Alukomen ne odlikujejo le sodoben videz in izjemna kvaliteta, temveč tudi tehnična dovršenost izražena v preprosti montaži in uporabi. Izdelki so pakirani v lično varovalno embalažo, ki varuje izdelke med transportom. Priložena so tudi slikovna navodila in ostali tehnični podatki.

Certifikat

Številni izdelki imajo certifikate kakovosti, na njih pa so bili izvedeni tudi tehnični testi na osnovi mehanske vzdržljivosti. Linija Mollis je v register patentov vpisana pod številko WO/2007/145601 kot patent tehnološke izdelave in oblikovanja. Tehnologija izdelave je novost na svetovnem trgu tega segmenta in omogoča širšo paleto površinskih obdelav kot jo imajo produkti konkurence

Razvoj opreme

Skupina, ki razvija opremo mesečno nadgrajuje izbor rešitev, tehnološko dovršenost izdelkov, moderno obliko, funkcionalnost in preprostost. Varnost in vzdržljivost opreme imata glavno prioriteto. Vsak prototip je tehnično preizkušen, in s svojo funkcionalnostjo in estetiko služi uporabniku.

Storitve

Naše številne reference so dober dokaz uspešnega sodelovanja z našimi strankami. Skrb za stranko se začne že s prvim kontaktom. Naši prodajalci vam bodo z veseljem predstavili izdelke in vam svetovali pri vaši odločitvi. Obiščemo vas lahko na domu, delovnem mestu ali gradbišču.



Materials and packaging

We use the best material - aluminium that has heterogeneous working surface. The products of Alukomen group are not distinguished only by their modern appearance and extraordinary quality, but also by the technical perfection, expressed in the simplicity of mounting and use. The products are packaged in an elegant safety packaging, safeguarding the product during transport. Instructions with pictures and other technical specifications can also be found enclosed.

Certificate

Numerous products have certificates of quality and in addition had technical tests on the basis of mechanical endurance performed on them. The Mollis collection is registered in the register of patents under the number WO/2007/145601 as a patent of technological manufacture and design. The technology of manufacture is a novelty in the world market of this segment and allows for a broader spectrum of surface treatments than the products of competition.

The development of equipment

The group developing the equipment is in charge of monthly upgrades of the selection of solution, technological completion of the products, modern form, functionality and simplicity. Safety and sturdiness of the equipment have the topmost priority. Each prototype is technically tested and serves the user with its functionality and aesthetics.

Services

Our numerous references are a good evidence of successful cooperation with our clients. The care for a customer begins with the first contact. Our salesmen will be delighted to present our products to you and give an advice regarding your decision. We can visit you at your home, workplace or construction site.

tipologije vrat in sten

door and wall typologies



pozicija artikla
article position



tip/type A



tip/type B



tip/type C

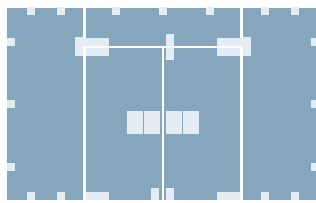

tip/type D

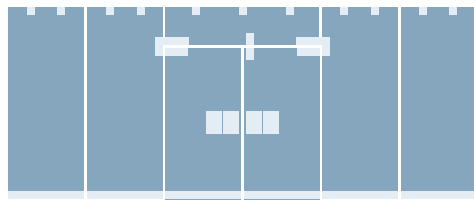

tip/type E

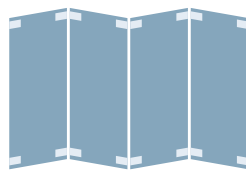

tip/type F

simboli

symbols



tipologija steklenih vrat
glass door typology



maksimalne dimenzije stekla
maximal glass dimensions



debeline stekla
glass thicknesses



maksimalna teža stekla
maximal glass weight

linija Mollis
Mollis collection



A40M05/G

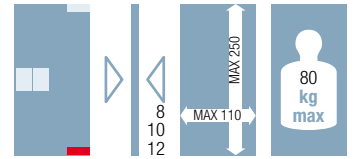

spodnji tečaj krilnih vrat_lower door hinge

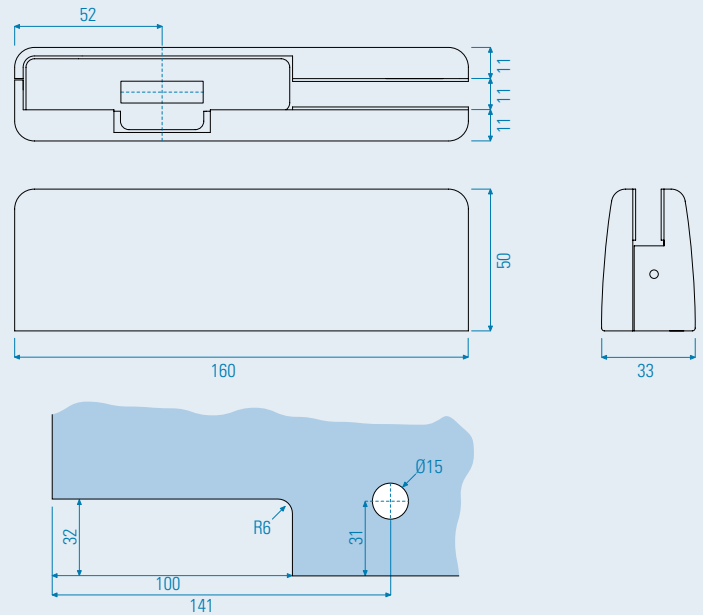

A41M05

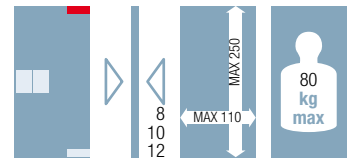

zgornji tečaj krilnih vrat_upper door hinge



uporablja se z artikli_used with articles
A-47, A-43, A-42

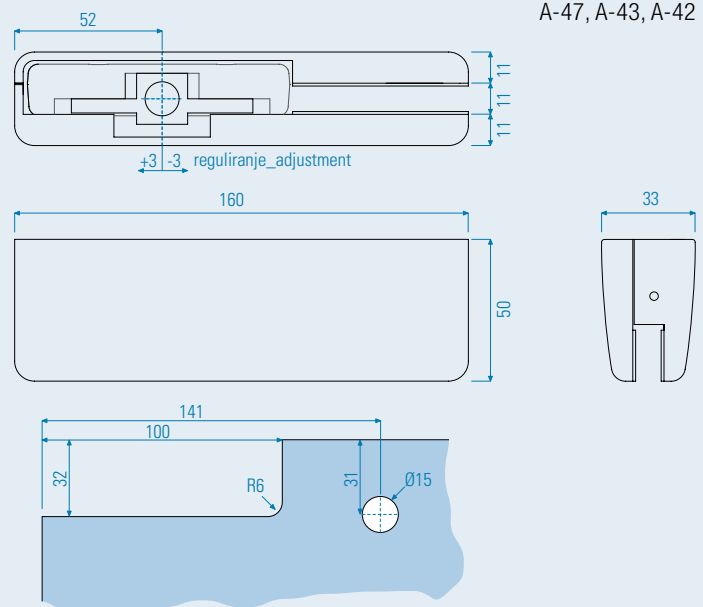

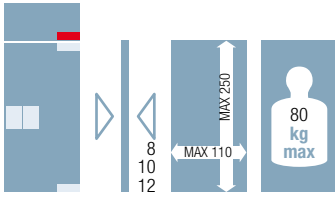

A42M05

vogalni tečaj vrat za spoj stene in nadsvetlobe_corner door hinge for joining the wall and toplight

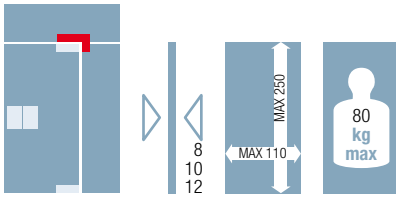
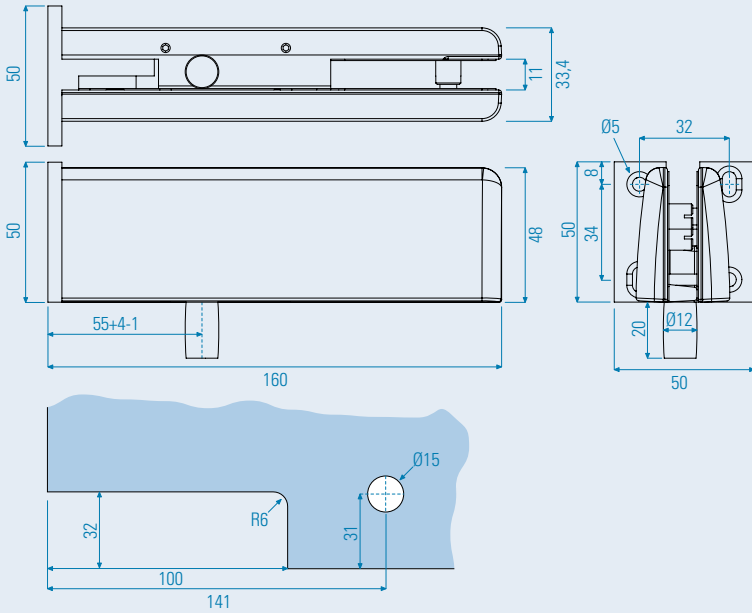

A43M05

vogalni tečaj vrat za spoj stranskega stekla in nadsvetlobe_corner door hinge for joining the lateral glass and toplight

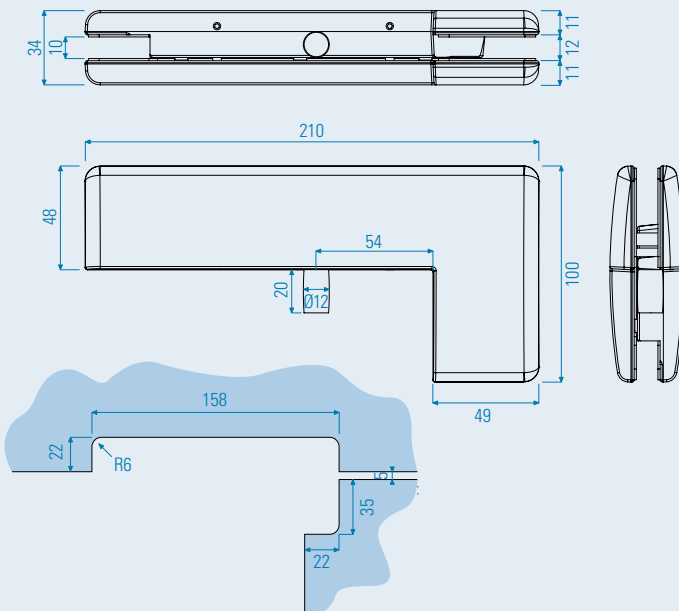

A60M05

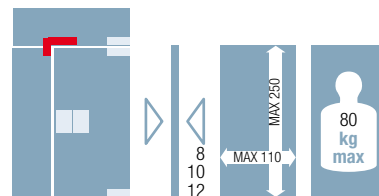

vogalni spoj stranskega stekla in nadsvetlobe_corner joint of lateral glass and toplight

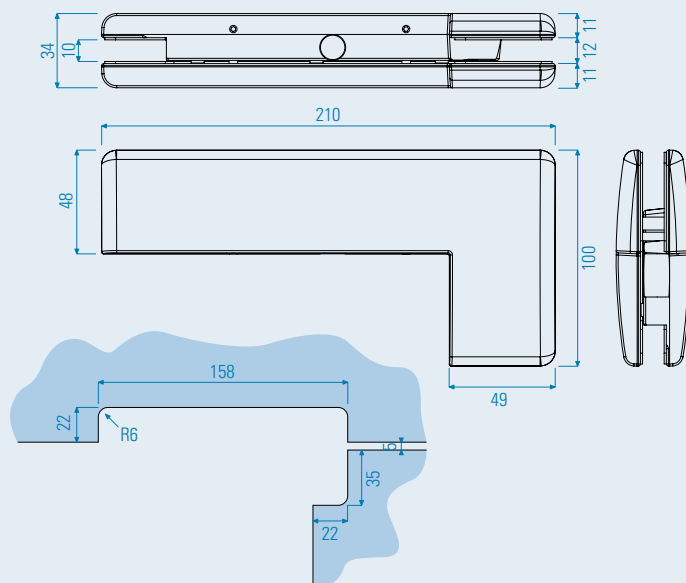

A61M05

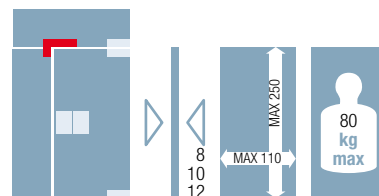

vogalni spoj stranskega stekla in nadsvetlobe z omejevalcem_corner joint of lateral glass and toplight with stoppage

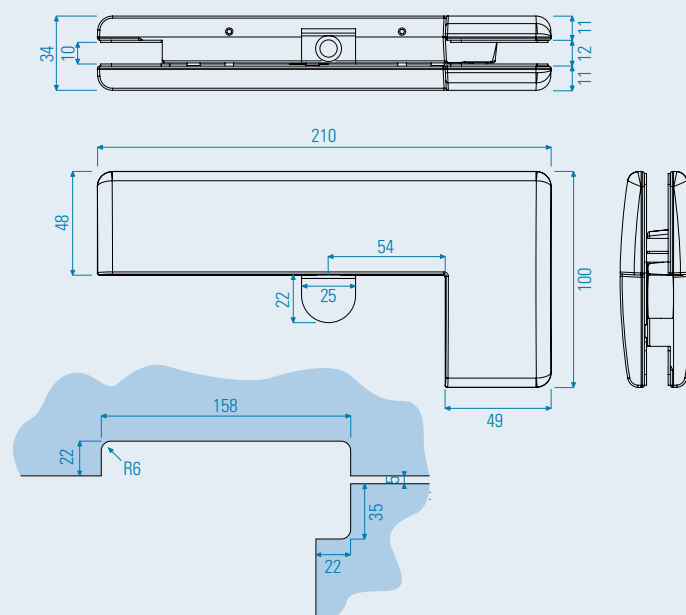



A131M05

protiključavnica za steklena vrata_glass door counterlock

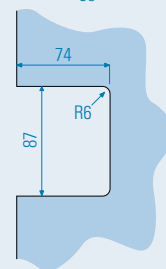
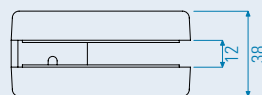
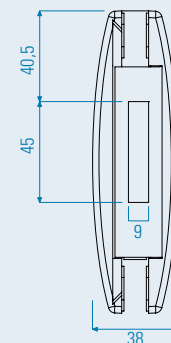
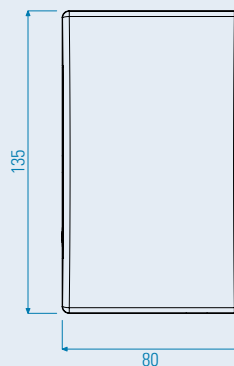
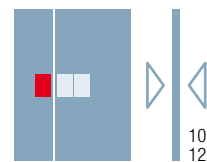

A132M05

ključavnica za krilna vrata_swing door lock

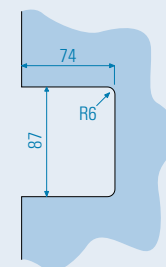
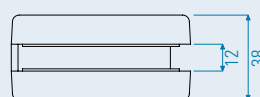
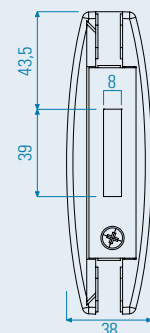
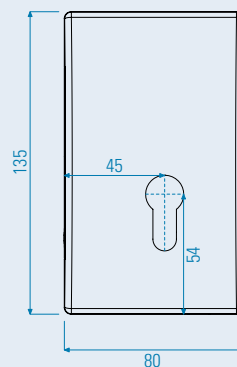
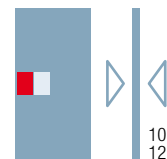

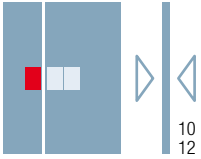

A131M05/S

protiključavnica za drsna vrata_counter lock for sliding door

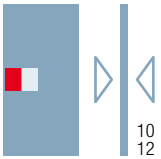
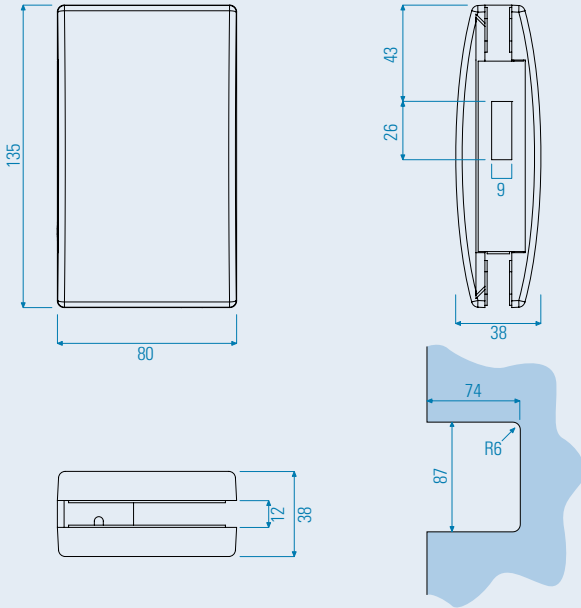

A132M05/S

ključavnica za drsna vrata_lock for sliding door

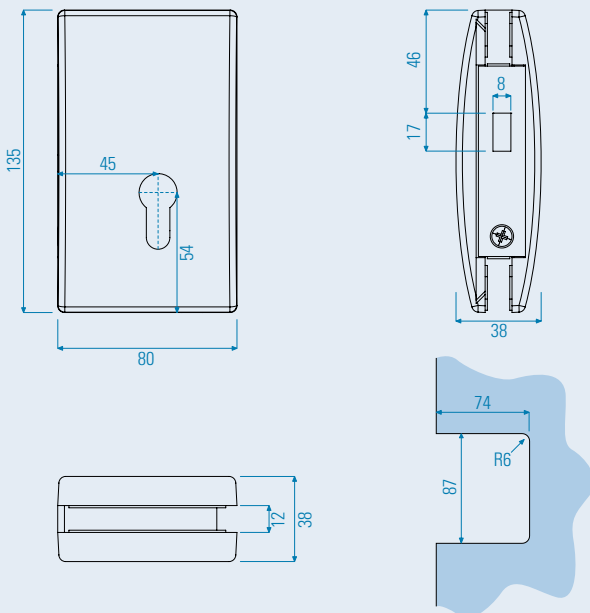

A3M05

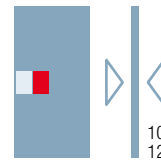

ročaj (par)_handle (couple)

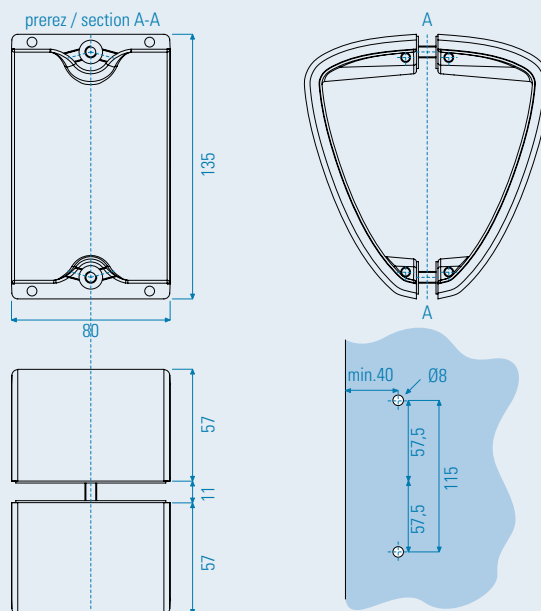

A3M05+A132M05

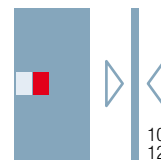

ročaj + ključavnica_handle + lock

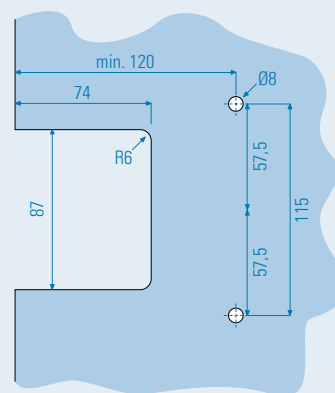



A74M05

spojni element za stekleno steno_glass-wall joint

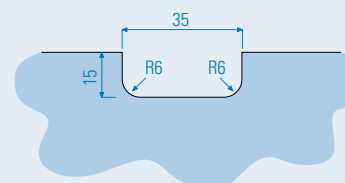
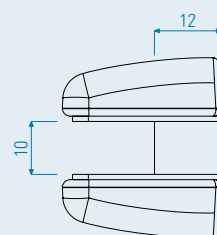
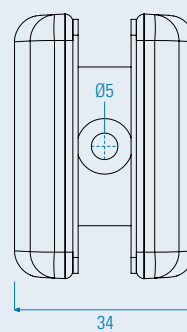
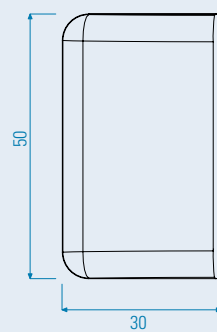
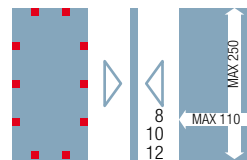

A78M05

spojni element za stekleno steno_glass-wall joint

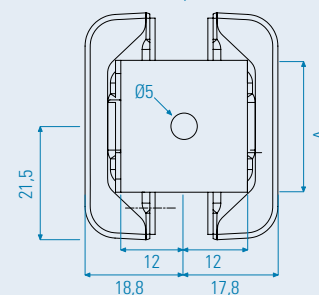
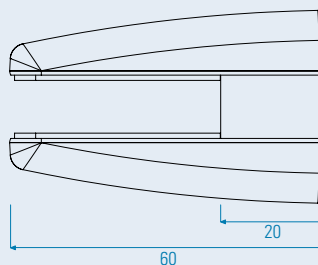
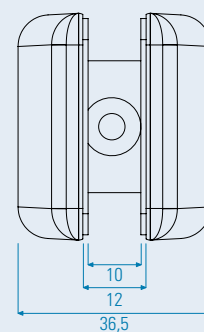
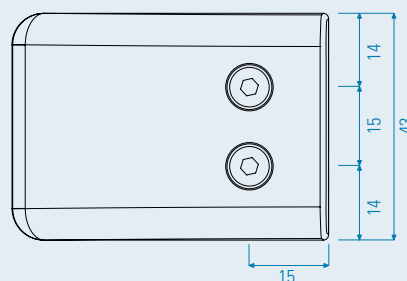
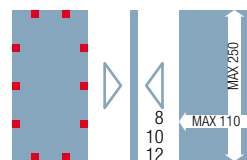

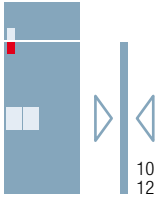

A110M05

zapah_glass door bolt

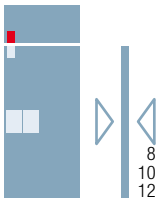
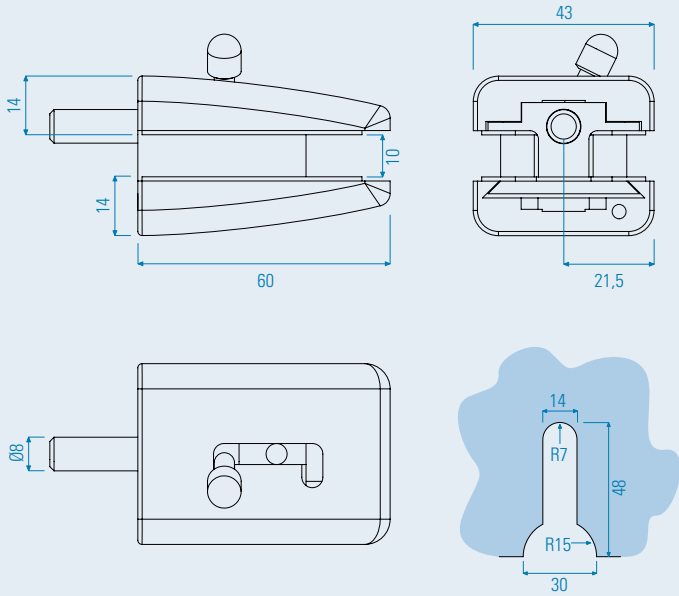

A111M05

protizapah_glass door counterbolt

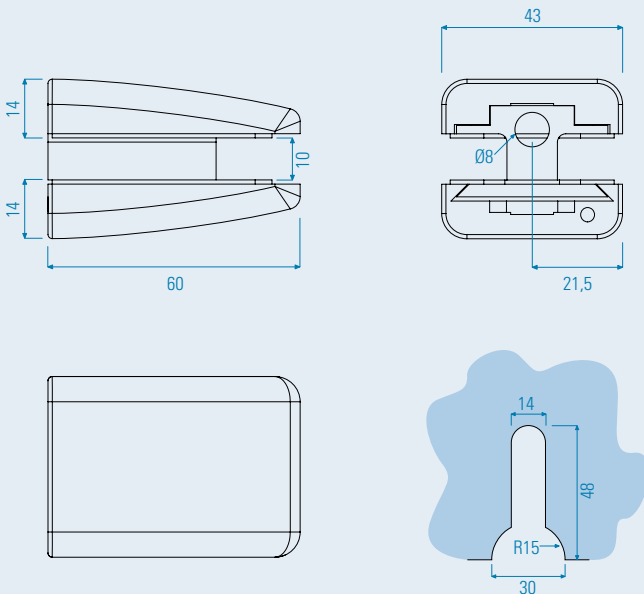

A180M05

spodnja letev za krilna vrata_swing door bottom slat

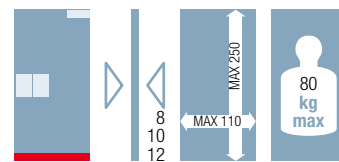

s tečajem in zapahom_with hinge and bolt

KODA_CODE	L	L1	L2	L/R
A180M05/TG/800/L	800	658	606	left
A180M05/TG/800/R	800	658	606	right
A180M05/TG/900/L	900	758	706	left
A180M05/TG/900/R	900	758	706	right
A180M05/TG/1000/L	1000	858	806	left
A180M05/TG/1000/R	1000	858	806	right
A180M05/TG/1200/L	1200	958	906	left
A180M05/TG/1200/R	1200	958	906	right
A180M05/TV/800/L	800	658	606	left
A180M05/TV/800/R	800	658	606	right
A180M05/TV/900/L	900	758	706	left
A180M05/TV/900/R	900	758	706	right
A180M05/TV/1000/L	1000	858	806	left
A180M05/TV/1000/R	1000	858	806	right
A180M05/TV/1200/L	1200	958	906	left
A180M05/TV/1200/R	1200	958	906	right

TG= Geze pravokotni tečaj (standard)_Geze rectangular hinge (standard)

TI= italijanski kvadratni tečaj_italian square hinge (on demand)

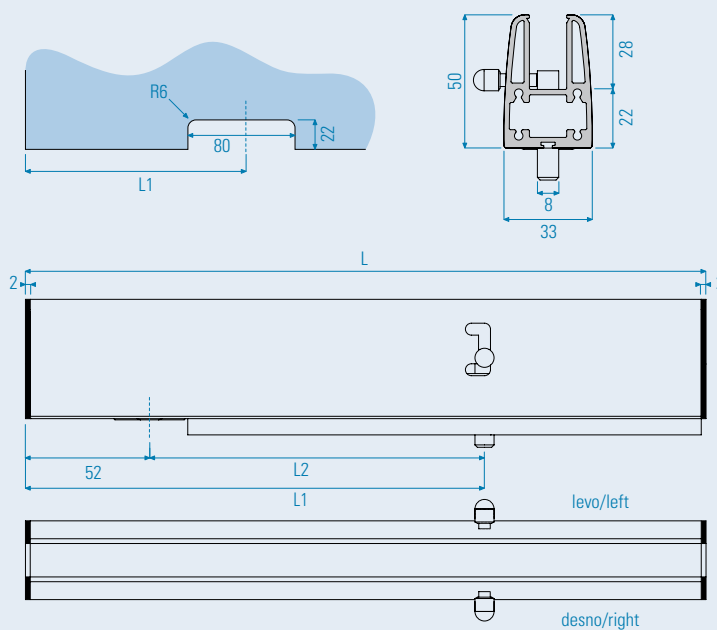

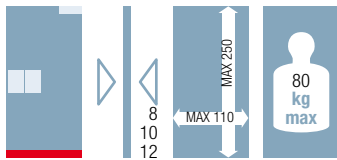

A181M05

spodnja letev za krilna vrata_swing door bottom slat



s tečajem in izrezom za cilinder_with hinge and cylinder cutting

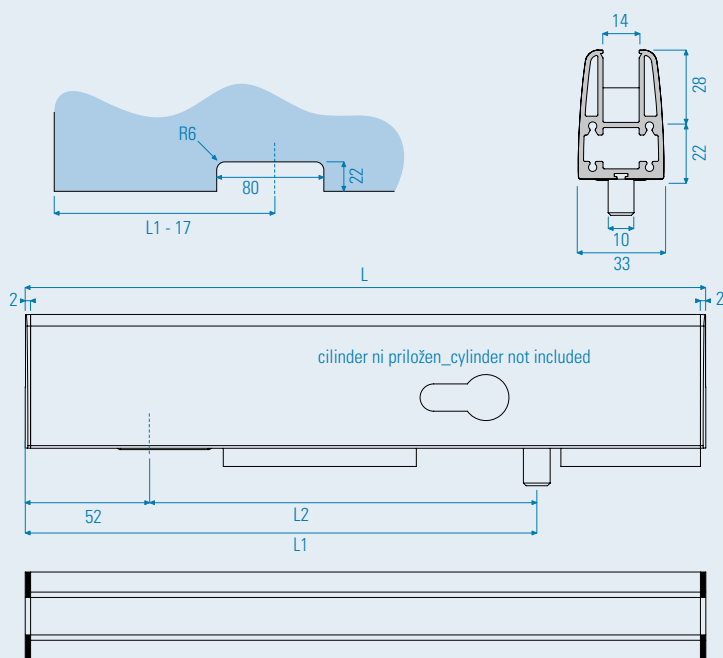

KODA_CODE	L	L1	L2
A181M05/TG/800	800	658	606
A181M05/TG/900	900	758	706
A181M05/TG/1000	1000	858	806
A181M05/TG/1200	1200	958	906
A181M05/TI/800	800	658	606
A181M05/TI/900	900	758	706
A181M05/TI/1000	1000	858	806
A181M05/TI/1200	1200	958	906

TG= Geze pravokotni tečaj (standard)_Geze rectangular hinge (standard)
TI= italijanski kvadratni tečaj_italian square hinge (on demand)

A182M05/SP

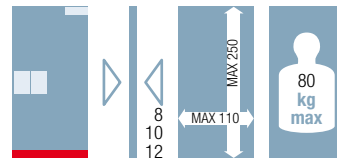

spodnja letev s tečajem za krilna vrata_wing door bottom slat with hinge



KODA_CODE	L
A182M05/TG/800	800
A182M05/TG/900	900
A182M05/TG/1000	1000
A182M05/TG/1200	1200
A182M05/TV/800	800
A182M05/TV/900	900
A182M05/TV/1000	1000
A182M05/TV/1200	1200

TG= Geze pravokotni tečaj (standard)_Geze rectangular hinge (standard)

TI= italijanski kvadratni tečaj_italian square hinge (on demand)

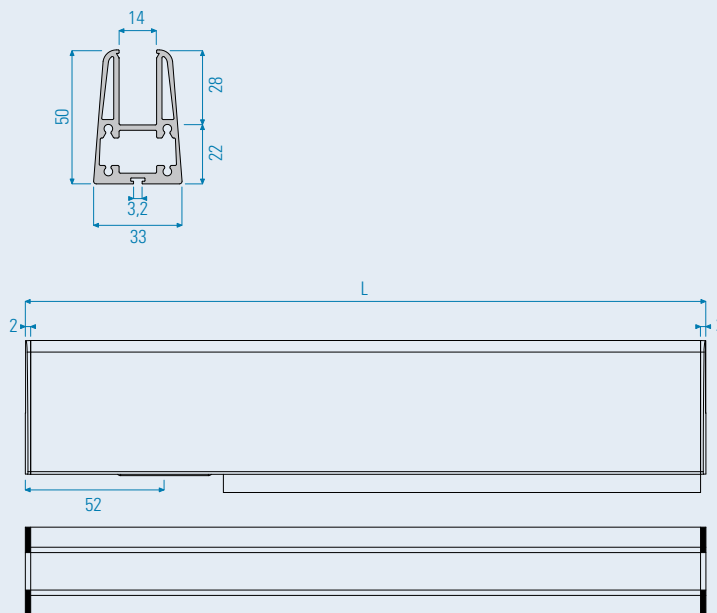

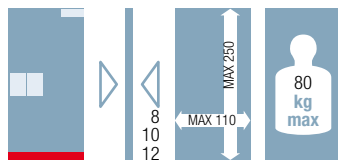

A182M05/ZG

zgornja letev s tečajem za krilna vrata_upper swing door slat with hinge

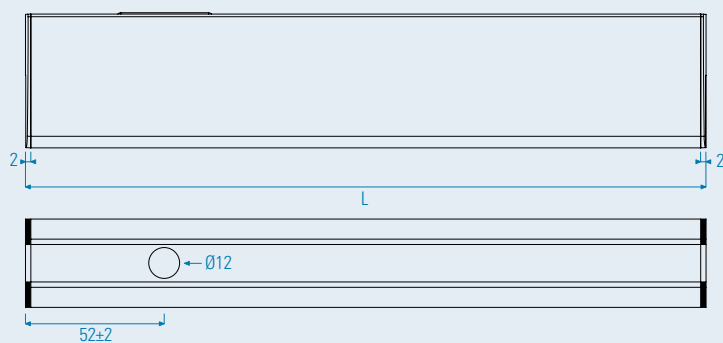
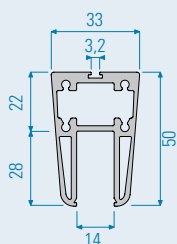

KODA_CODE	L
A182M05/TZ/800	800
A182M05/TZ/900	900
A182M05/TZ/1000	1000
A182M05/TZ/1200	1200

TZ= zgornji tečaj_upper hinge

A182M05

letev za krilna steklena vrata_slat for wing-opening glass door

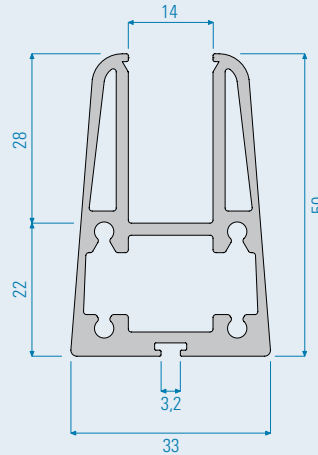
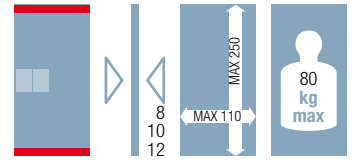

A188M05

končnik krilne letve za A182M05
A182M05 slat-ending



KODA_CODE

9951 A182M05 talna letev krilna L=5 m eloksirana nature
floor wind slat L=5 m, elox nature

9950 A182M05 talna letev krilna v metrih eloksirana nature
floor wind slat in meters, elox nature

A183M05

letev za fiksne steklene stene_fixed wall slat

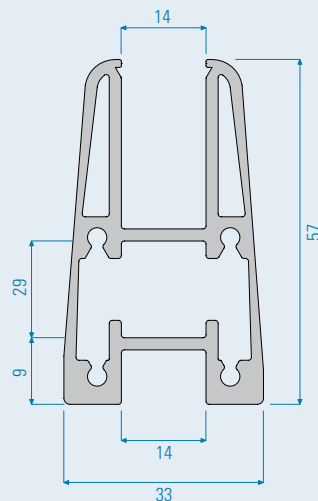
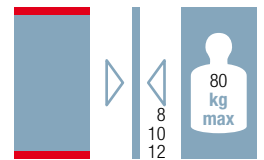

A186M05

končnik fiksne letve za A183M05
A183M05 slat-ending



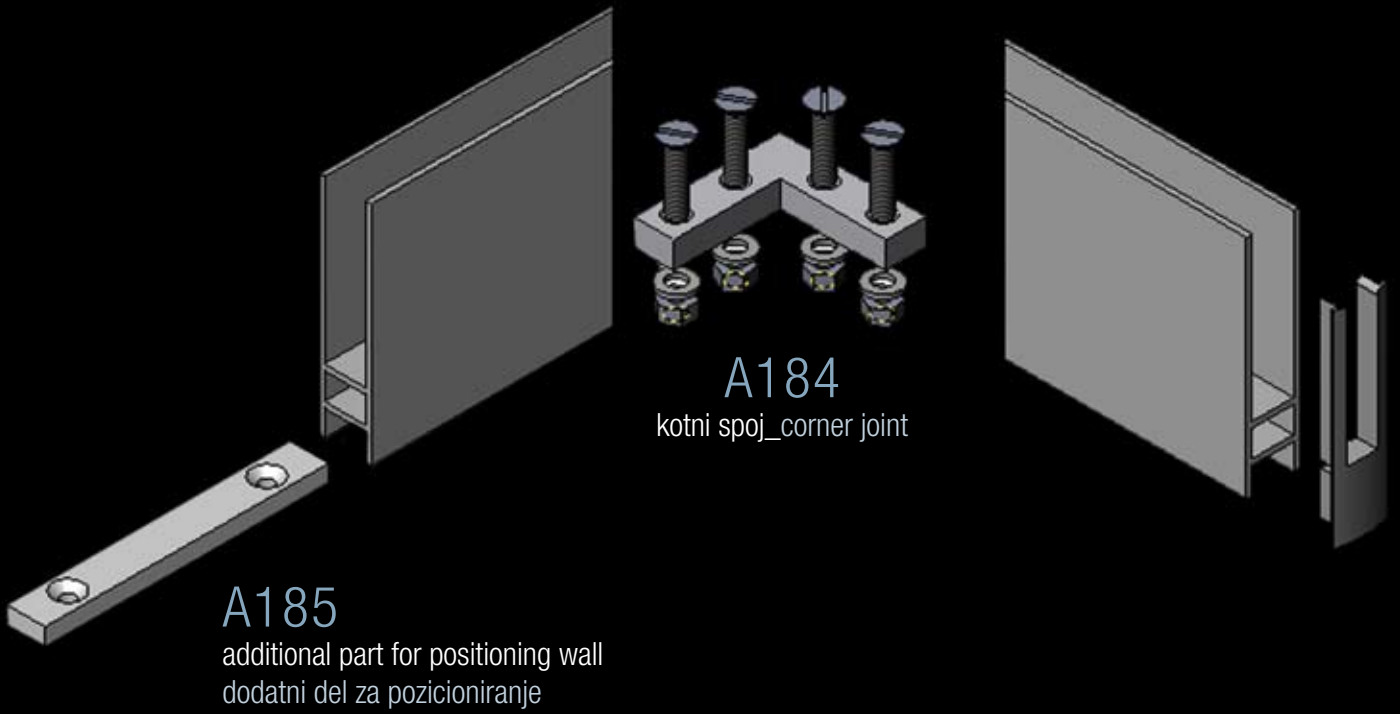

A189M05

T spoj fiksnih letev_T-joint for fixed wall

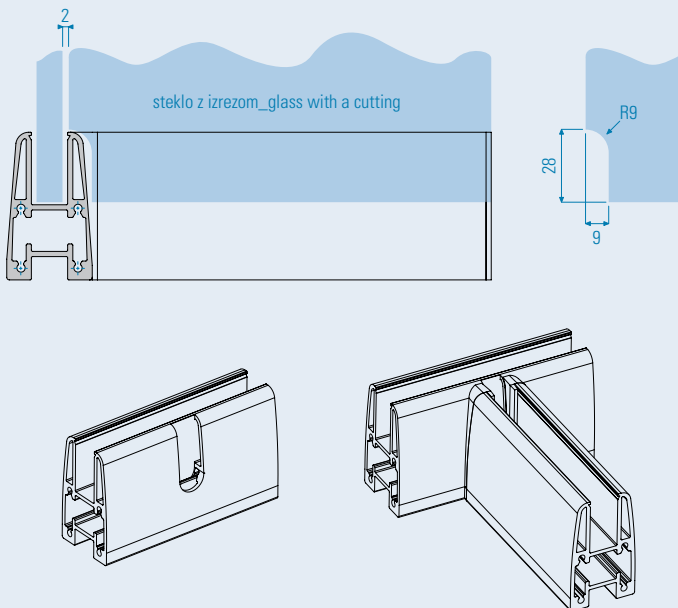

A192

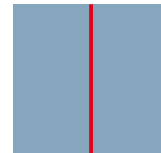

H profil_H profile



prerez / section B-B

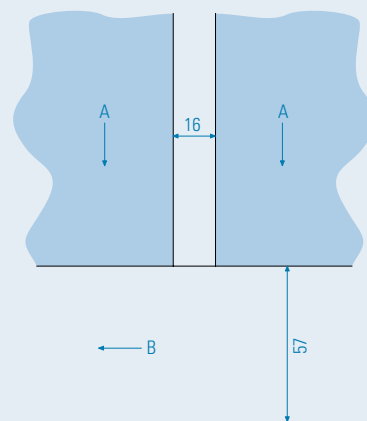
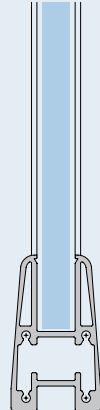

prerez / section A-A

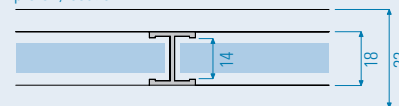

A193

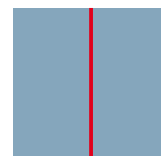

L profil_L profile



prerez / section B-B

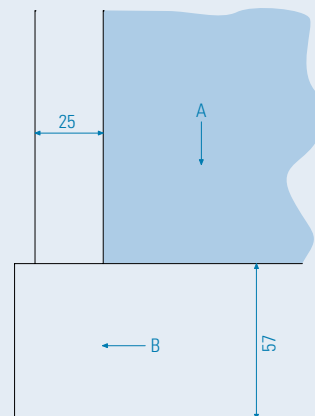
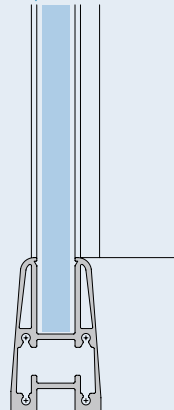

prerez / section A-A

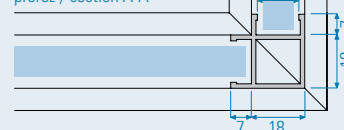

A194

U profil_U profile

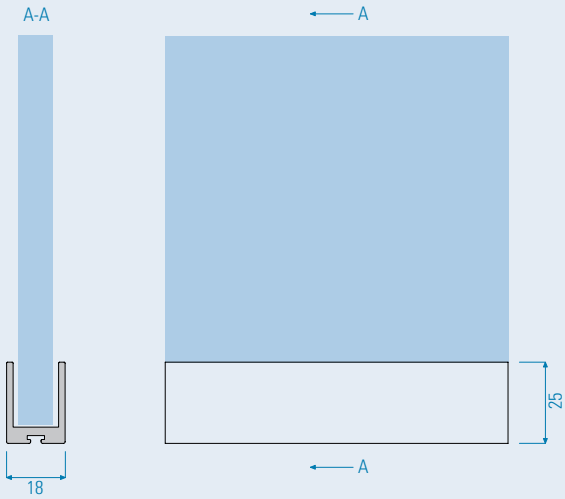

TESNILA GASKET



Črno tesnilo debeline 2 mm za steklo debeline 10 mm
black gasket 2 mm thick for 10 mm thick glass



Črno tesnilo debeline 3 mm za steklo debeline 8 mm
black gasket 3 mm thick for 8 mm thick glass

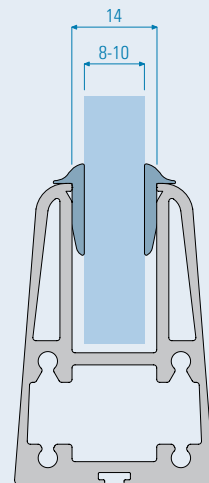
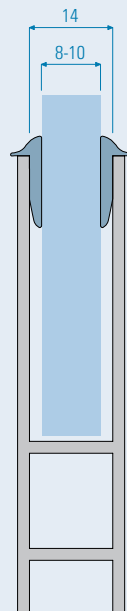

STEKLENA VRATA S PODBOJEM

GLASS DOOR WITH DOORJAMB



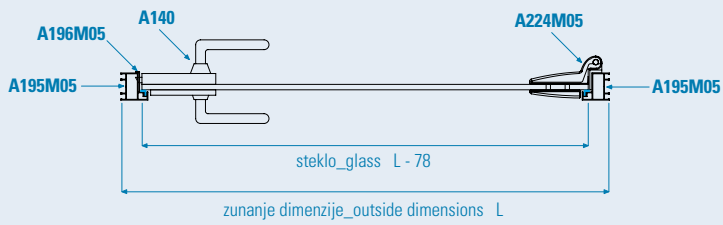
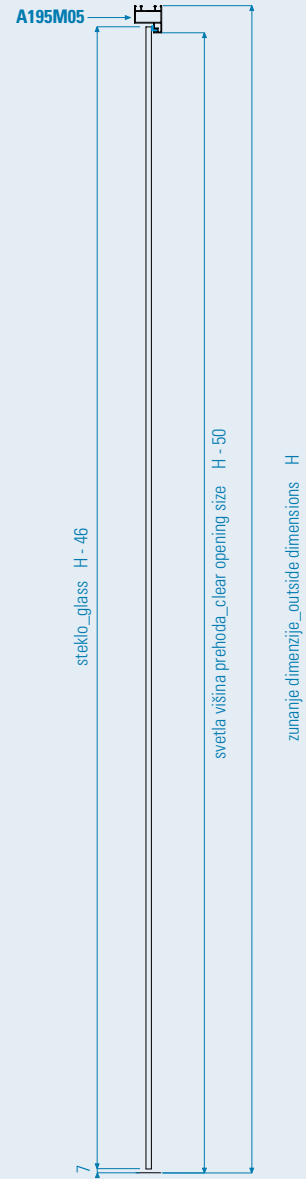
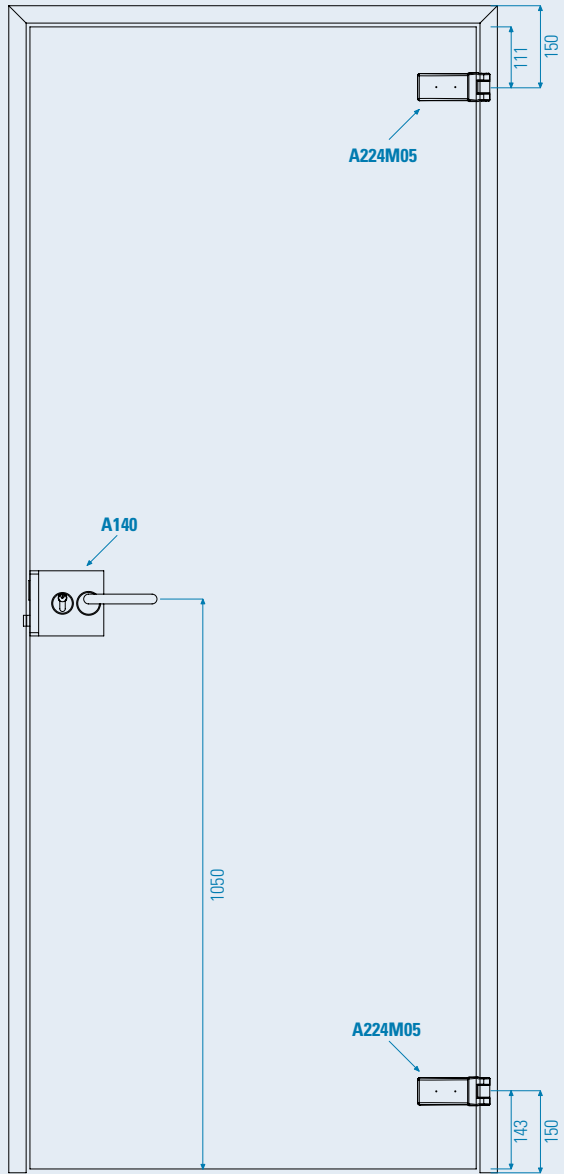

A195M05

podboj s pripiro_doorstep with stoppage

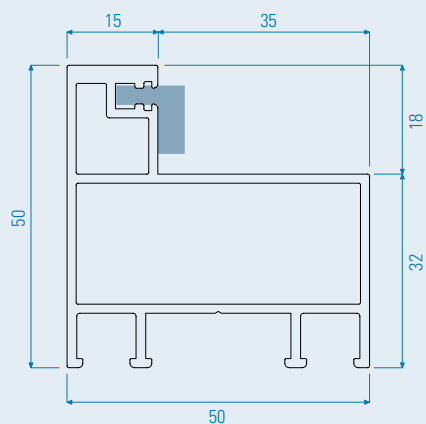
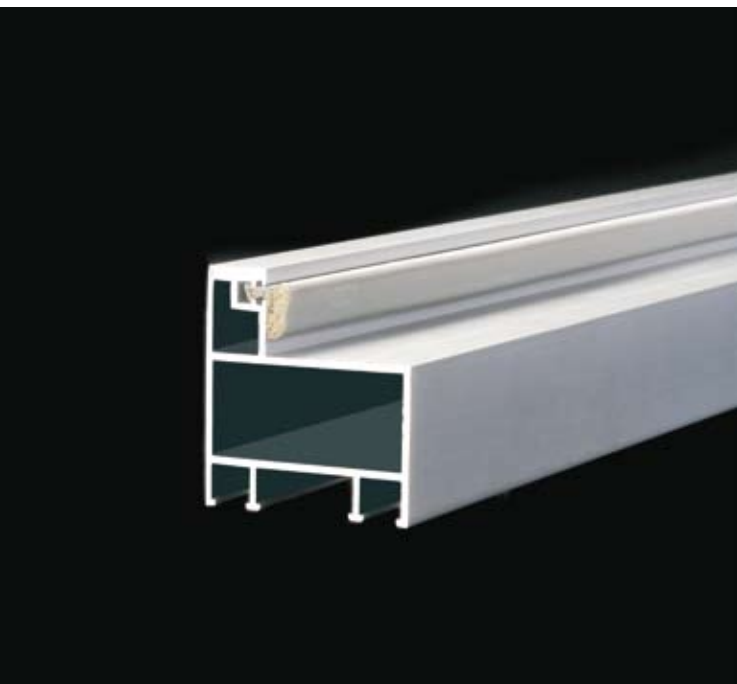

A196M05

ploščica iz nerjavečega jekla_stainless steel lock protection

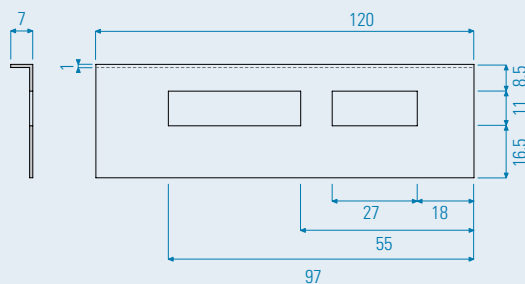

KODA_CODE

A196M05/D

desno_right

tehnična risba_technical chart

A196M05/L

levo_left



A196/Z

zapiralo za stekleno krilo
cylinder door closer

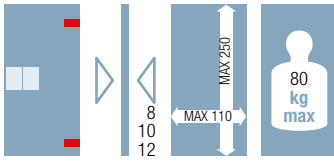

A224M05

tečaj za stekleno krilo in ALU podboj s pripiro_hinge for glass fold and ALU doorjamb with doorstep

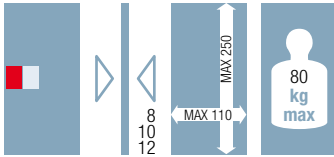
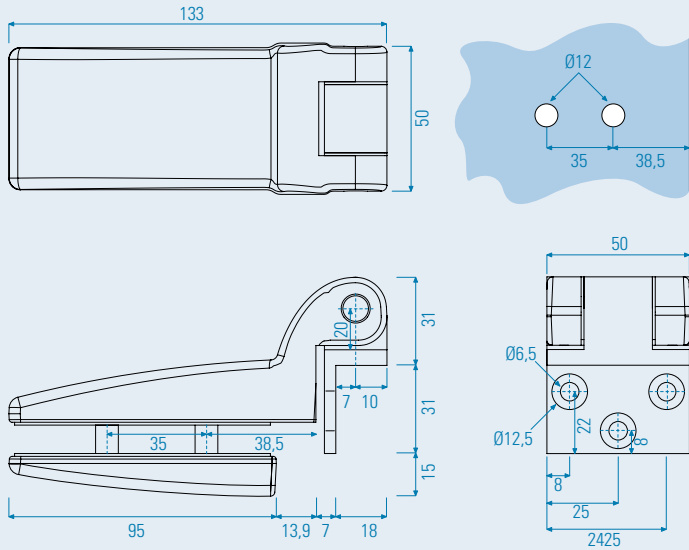

A140M05

ključavnica za stekleno krilo_lock for glass fold

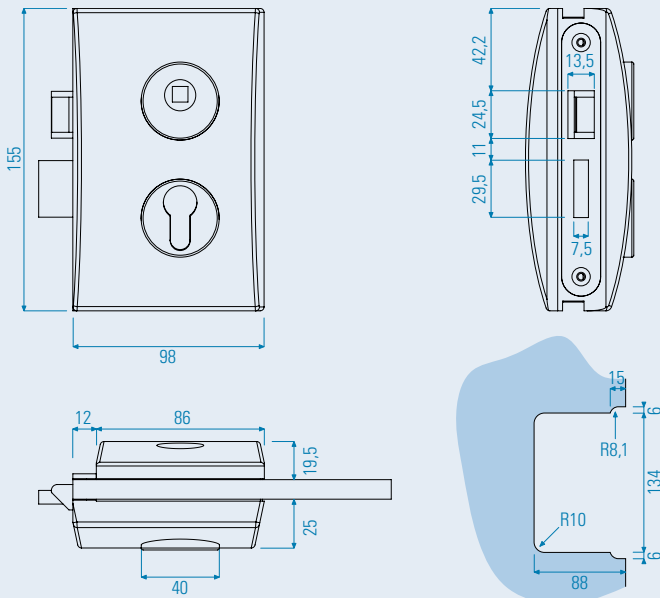

938/553 M18

masivna medenina, satin krom_mассив brass, satin krom

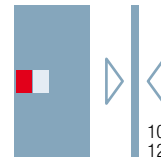

THEMA C 36915P

nerjaveče jeklo, satin inox_stainless steel, satin inox

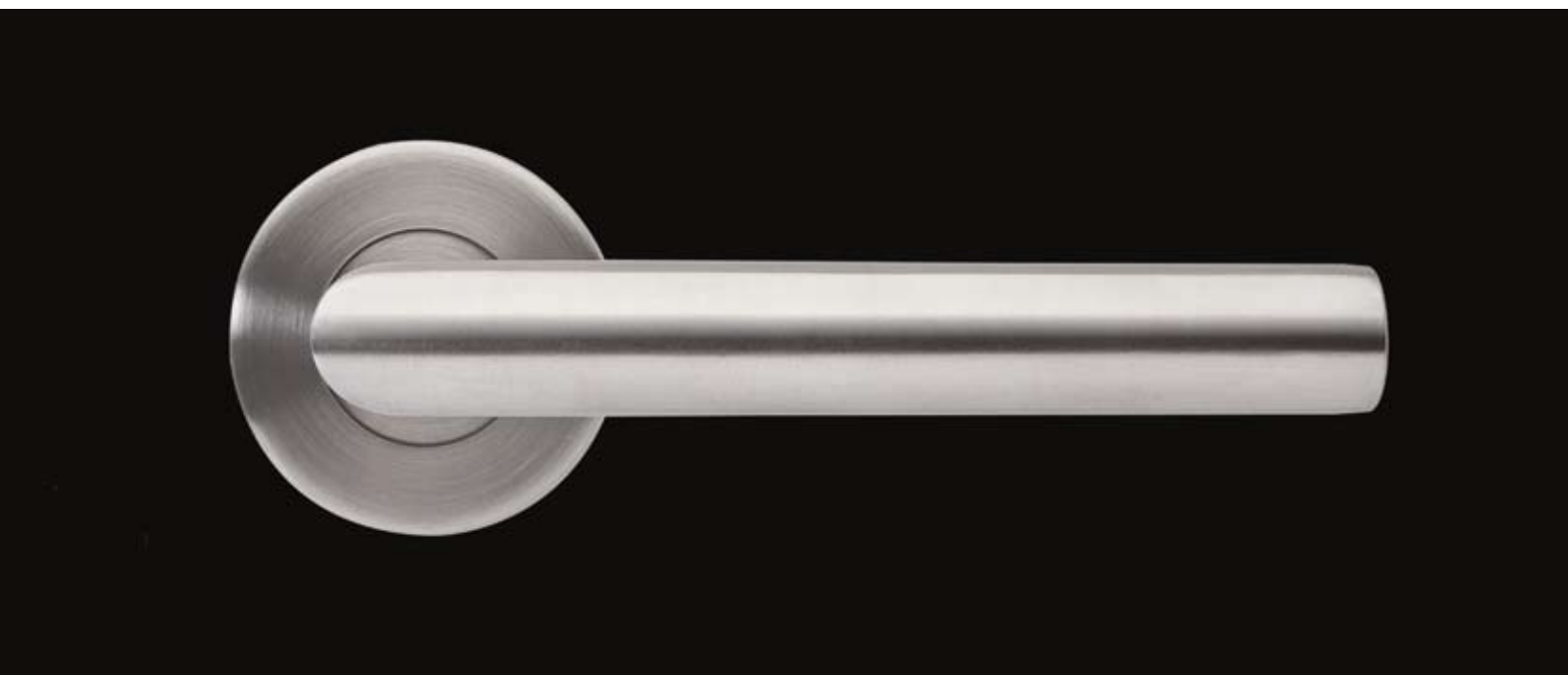
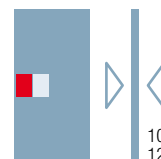

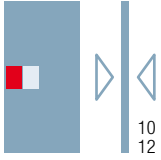

775/553 M18

masivna medenina, satin krom_massive brass, satin krom

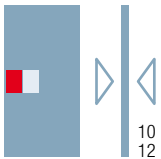
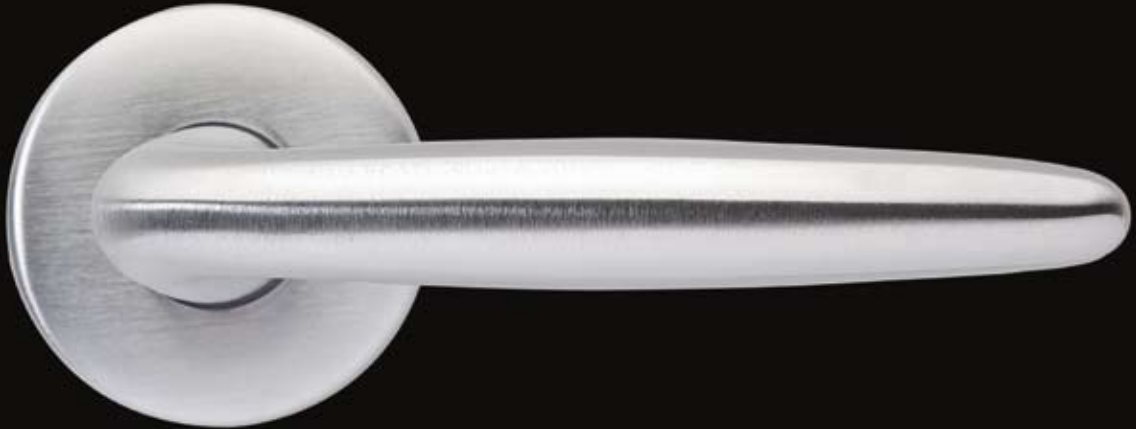

OTTERO 787/555 M18

masivna medenina, satin krom_massive brass, satin krom



A616M05

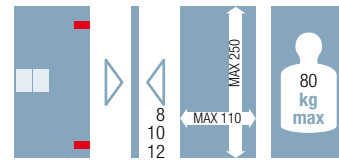

tečaj za stekleno krilo in leseni podboj_hinge for glass fold and wooden doorjamb

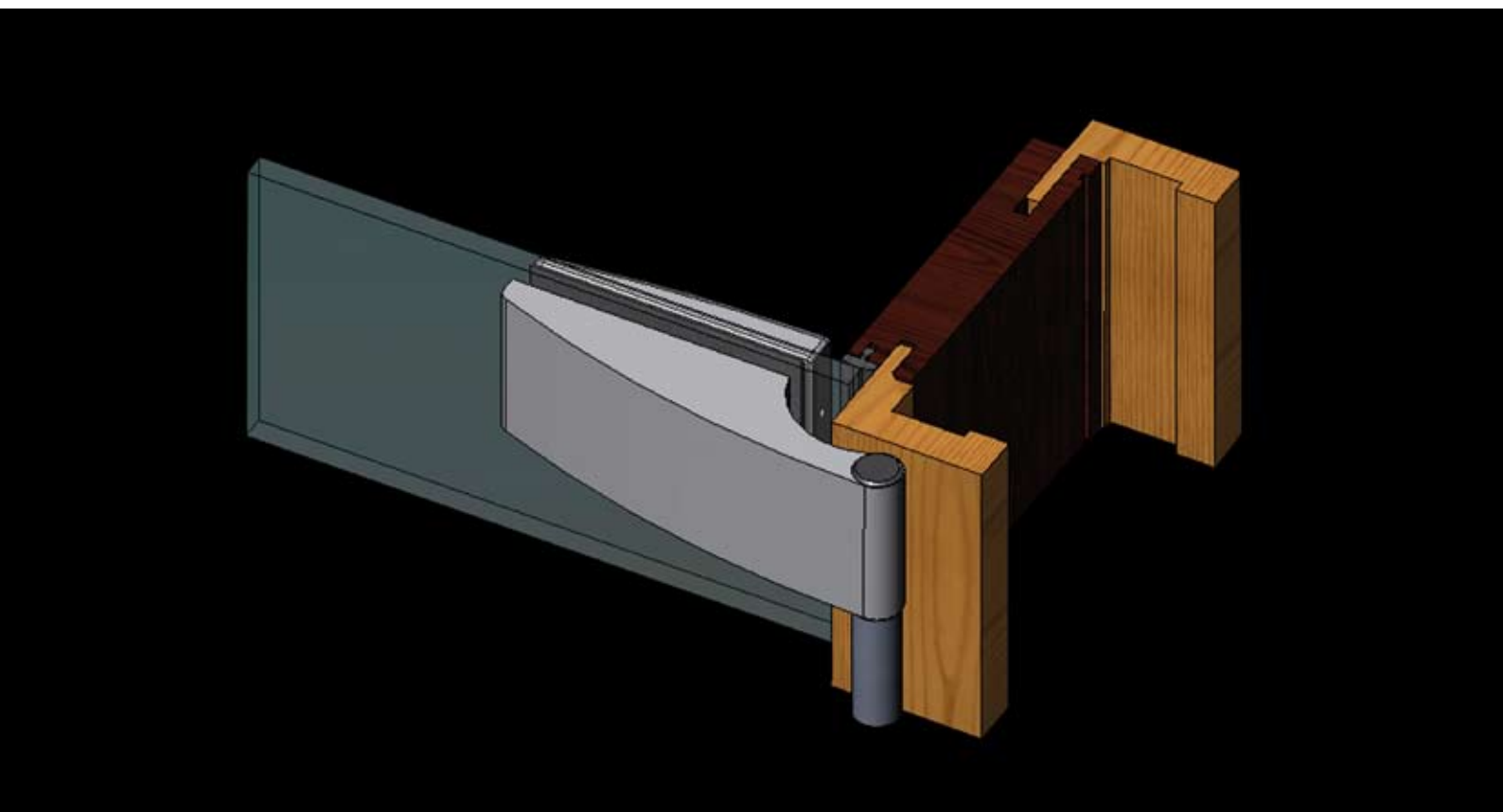
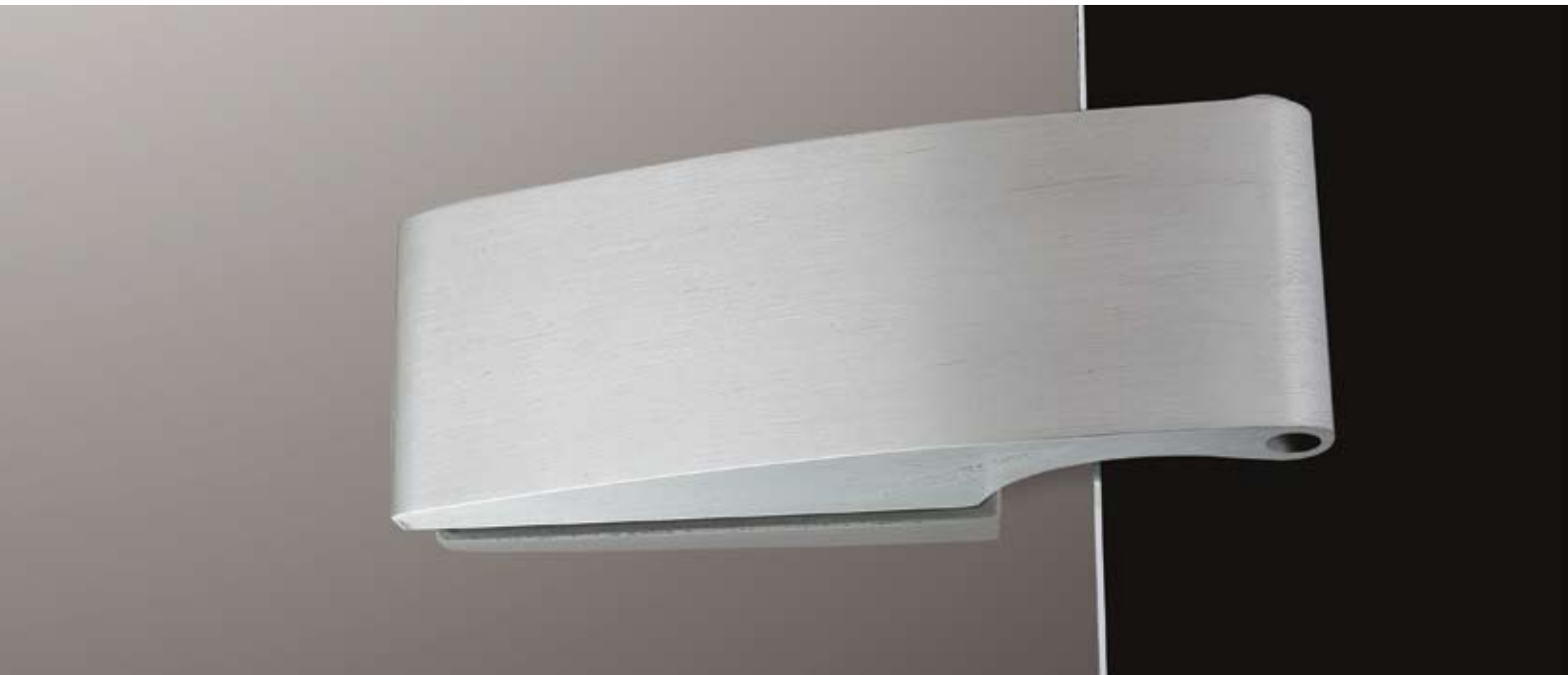

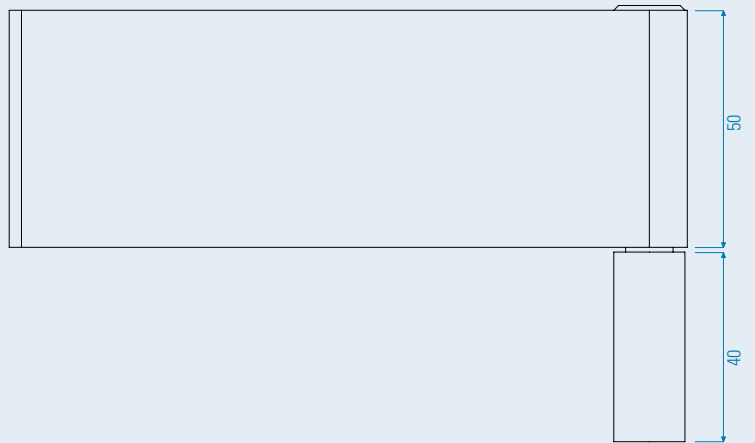
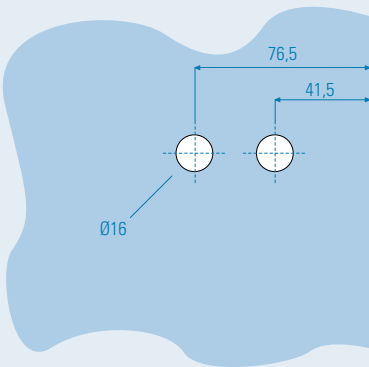
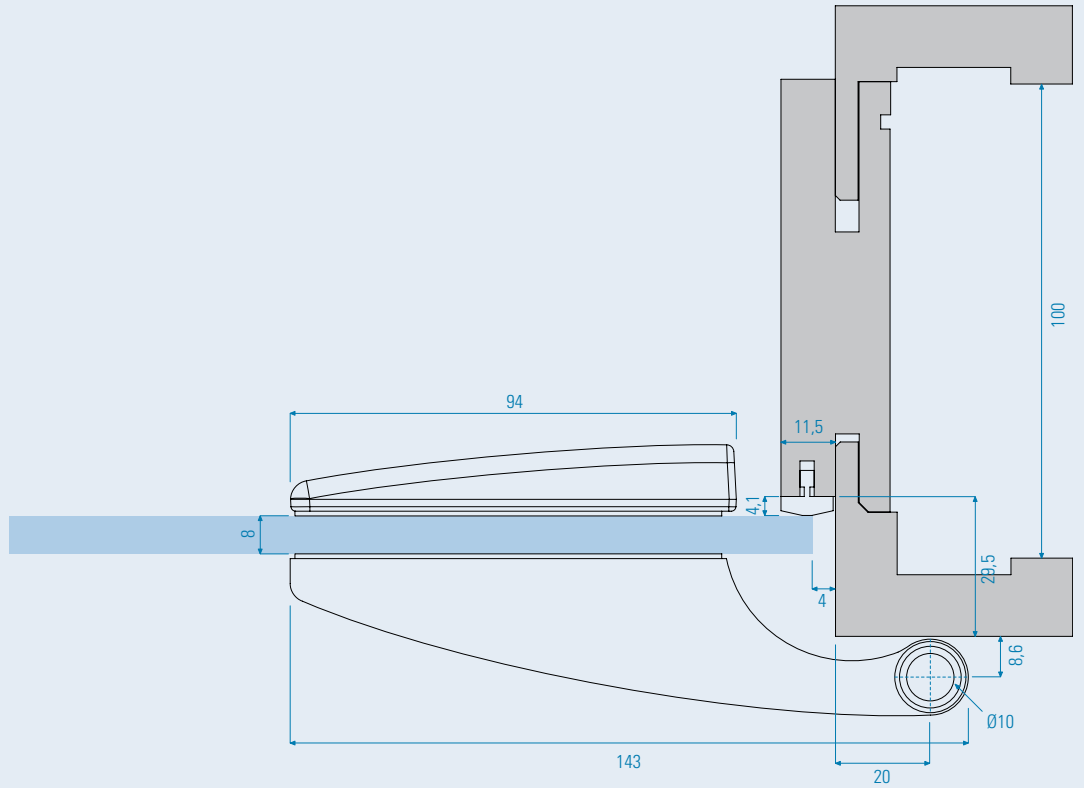

linija Durus

Durus collection



A-1

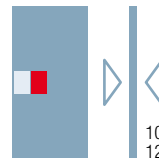

okrogli ročaj fi 12cm_doorknob fi 12cm

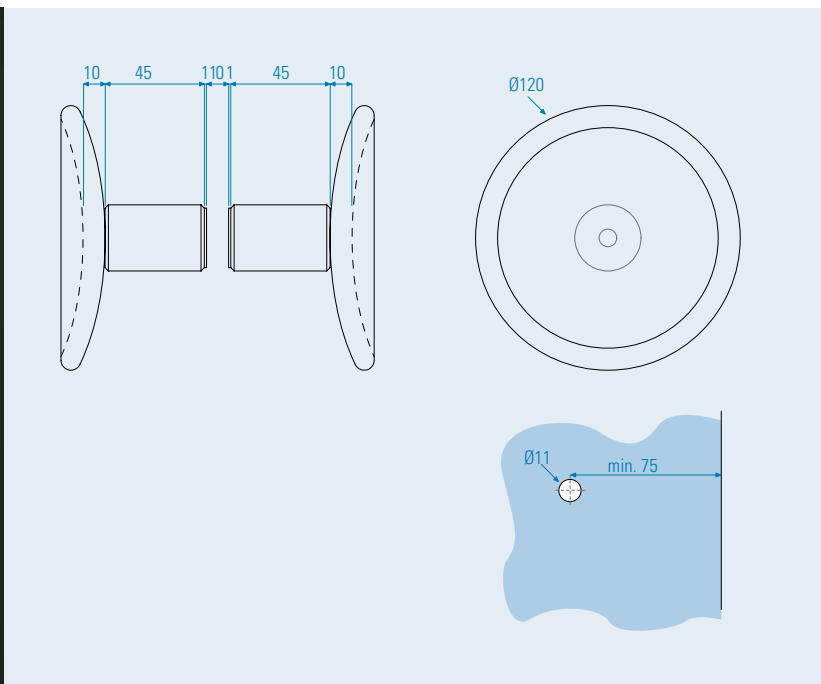

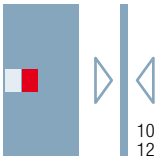

A-3

pravokotni ročaj 300 x 100_rectangular handle 300 x 100

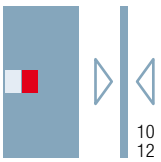
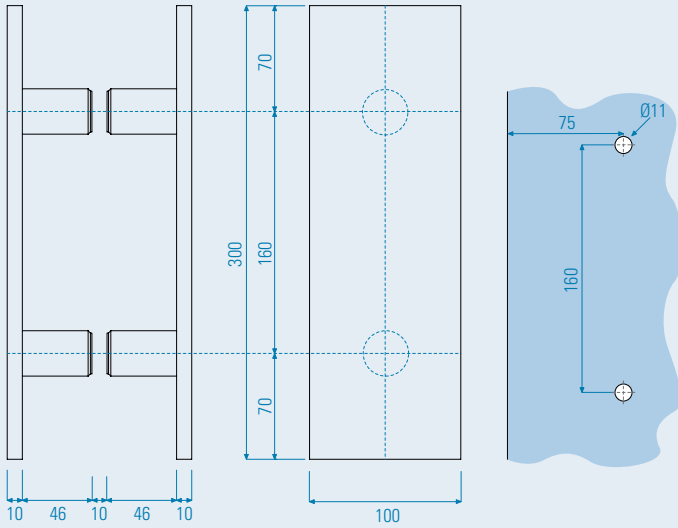

A-6

okrogel ročaj_doorknob

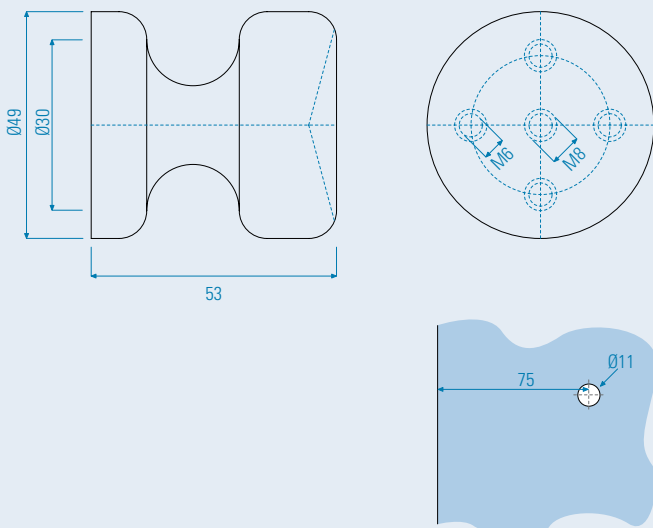



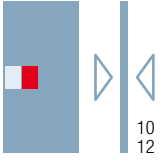

A-7

cevasti ročaj_tubular handle

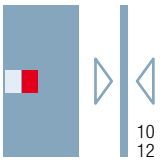
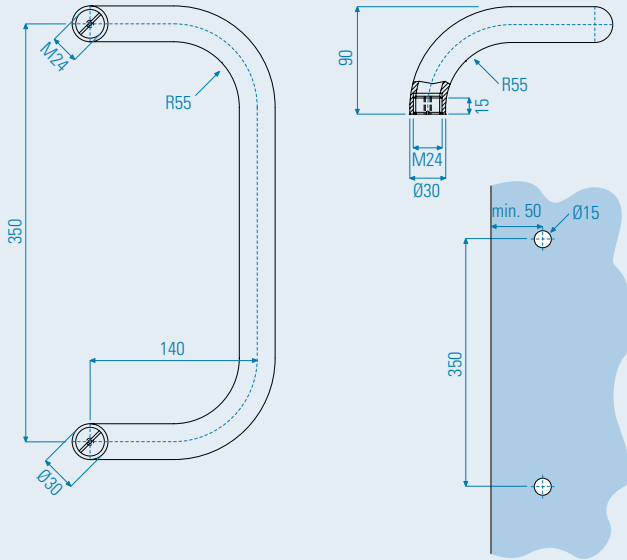

A-8

cevasti ročaj_tubular handle

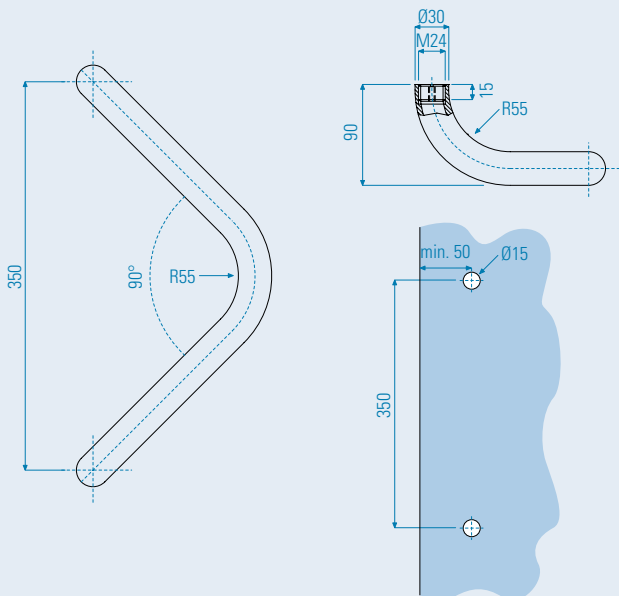

A-10

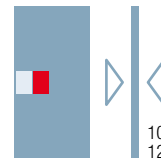

cevasti ročaj_tubular handle

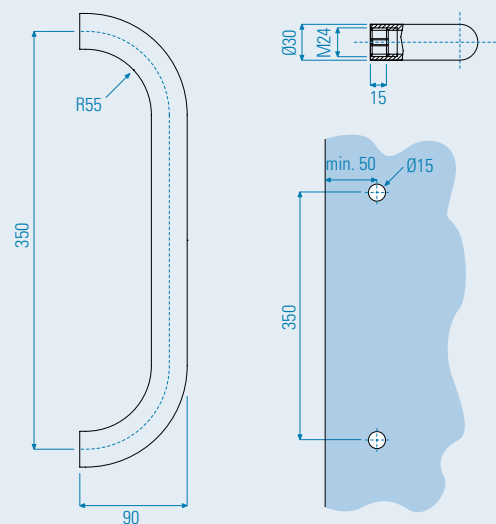

A-11

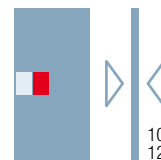

cevasti ročaj_tubular handle

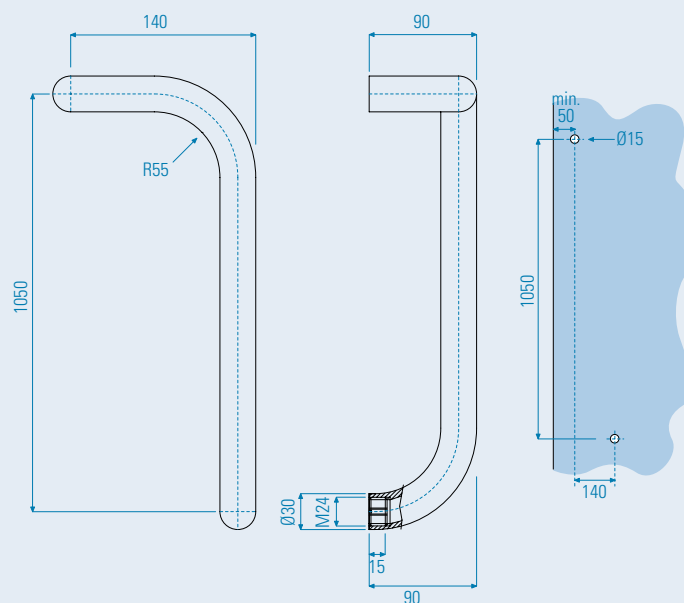

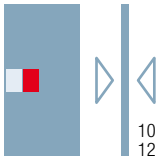

A-14

cevasti ročaj_tubular handle

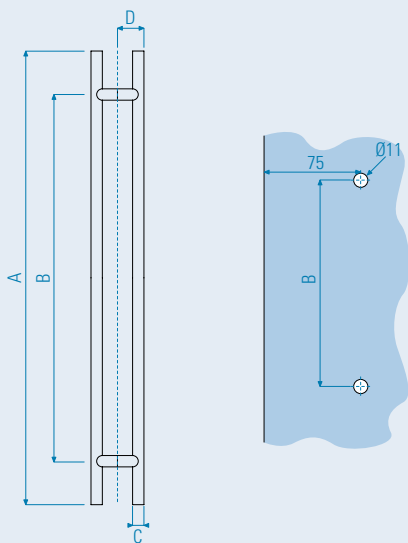

ALUMINIJ_ALUMINIUM

TIP_TYPE	A	B	C	D
A14 1800 AL	1800	1600	Ø30	70
A14 1200 AL	1200	1000	Ø30	70
A14 1000 AL	1000	800	Ø30	70
A14 600 AL	600	400	Ø30	70
A14 300 AL	300	160	Ø30	70

INOX

TIP_TYPE	A	B	C	D
A14 1800 I	1800	1600	Ø38	80
A14 1200 I	1200	1000	Ø38	80
A14 600 I	600	400	Ø32	72

A-15 A-16

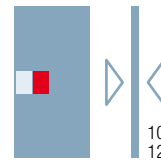

(nalepljen) ročaj za za drsna vrata_handle (sticked on) for sliding door

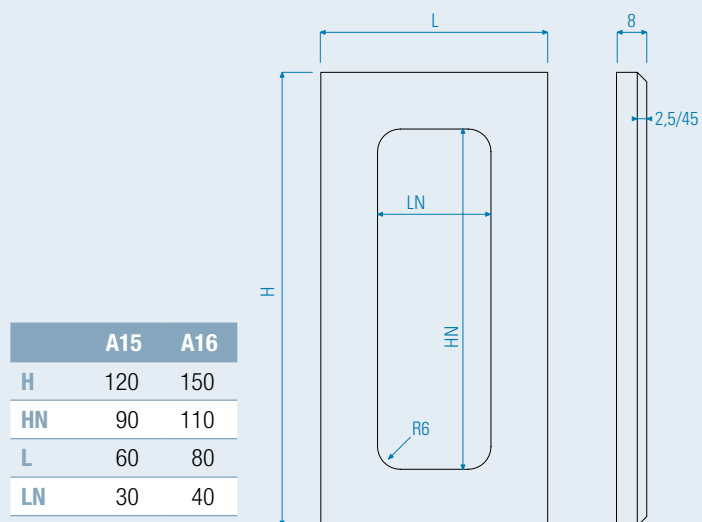

A-17

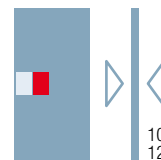

ročaj za tuš kabino_shower door knob

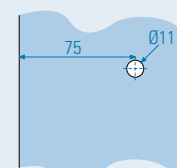
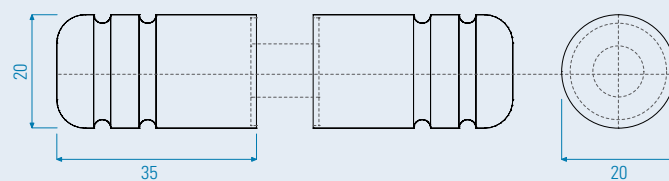

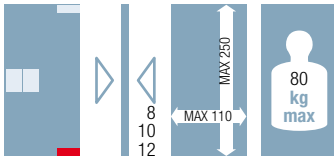

A-40

spodnji tečaj z Geze utorom_bottom hinge with Geze inlet piece

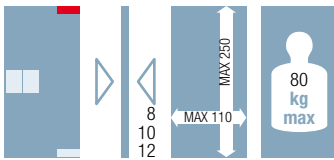
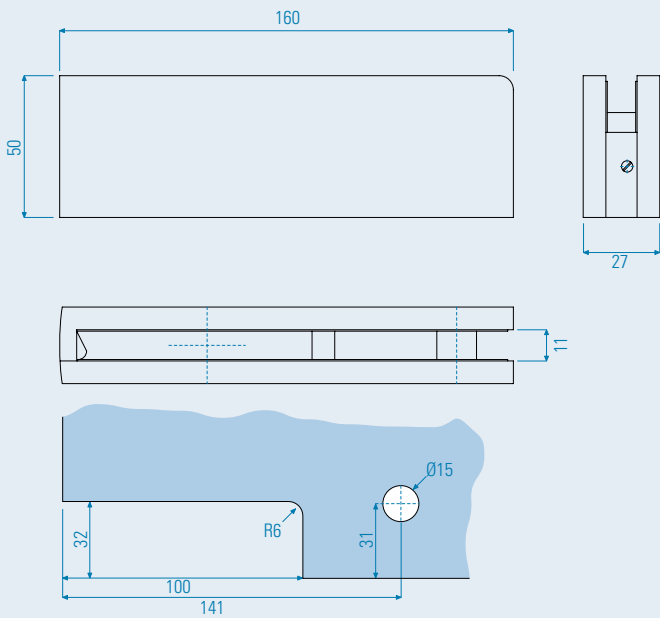

A-41

zgornji tečaj z utorom_top hinge with inlet piece

uporablja se z artikli_used with articles
A-47, A-43, A-42

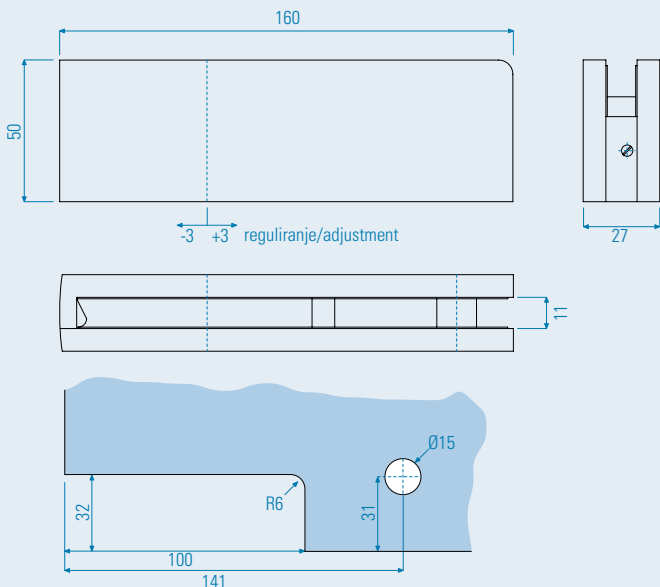

A-42

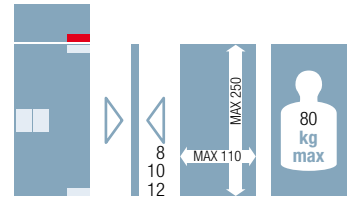

vogalni tečaj vrat za spoj stene in nadsvetlobe_corner door hinge for joining the wall and toplight

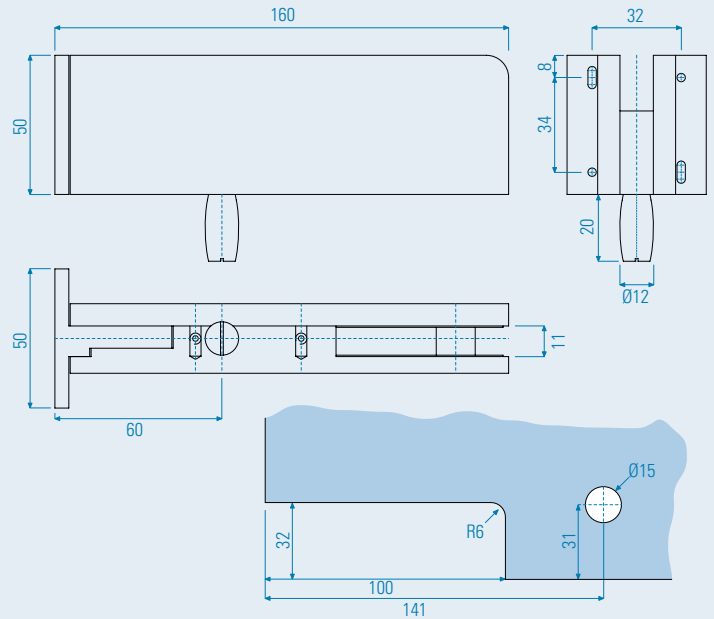

A-43

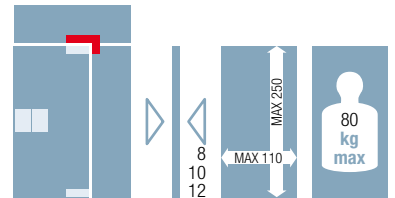

vogalni tečaj vrat za spoj stranskega stekla in nadsvetlobe_corner door hinge for joining the lateral glass and toplight

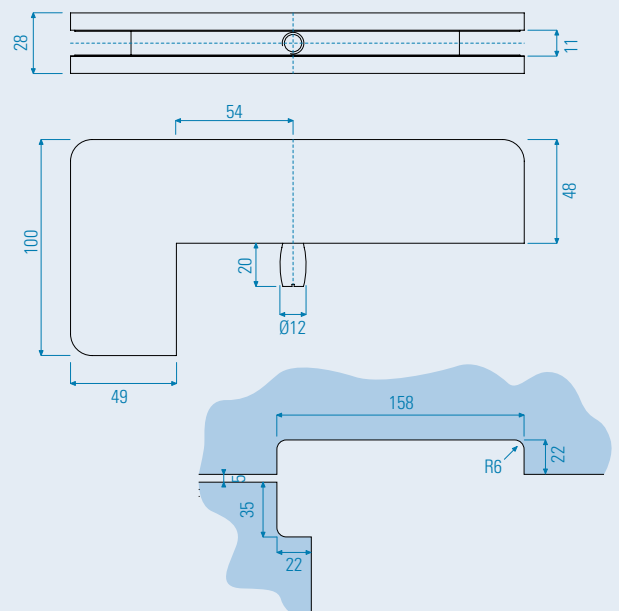

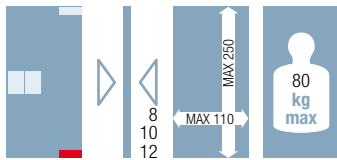

A-50

spodnji tečaj_bottom door hinge

s pripiro, uporabljati z A52
for door with stoppage, use with A52

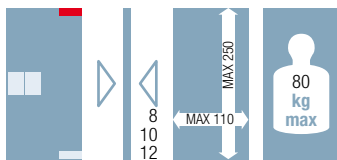
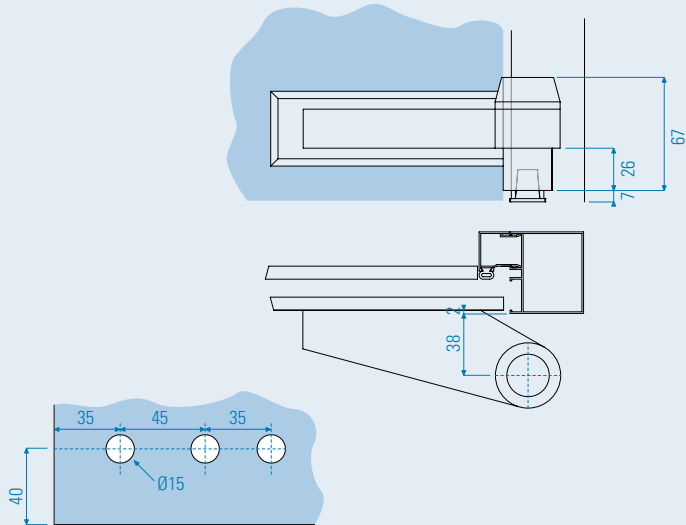

A-51

zgornji tečaj za stekleno krilo s pripiro_upper hinge for door with doorstep

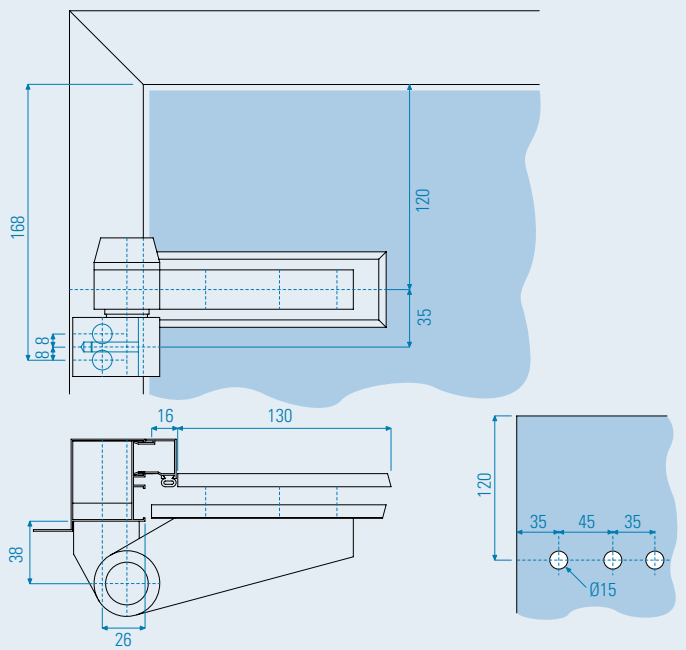



A-52

del zgornjega tečaja_top hinge part

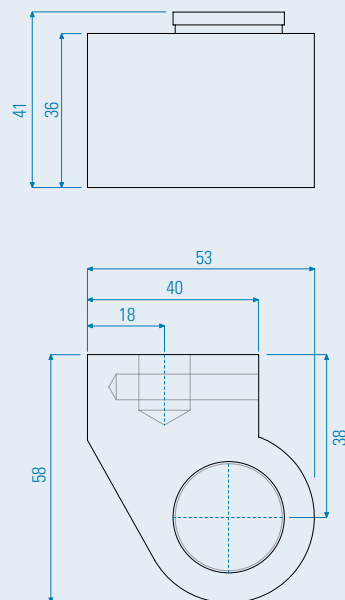

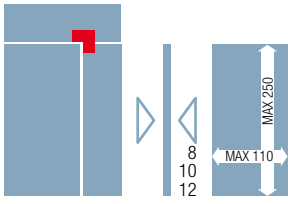

A-60

vogalni spoj stranskega stekla in nadsvetlobe_corner joint of lateral glass and toplight

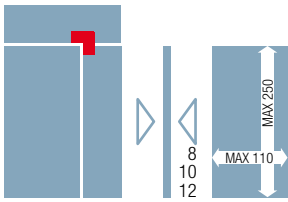
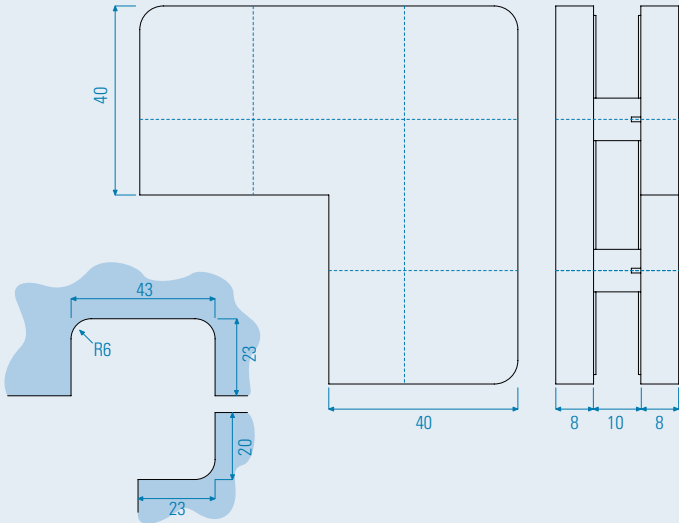

A-61

vogalni spoj stranskega stekla in nadsvetlobe z omejevalcem_corner joint of lateral glass and toplight with stoppage

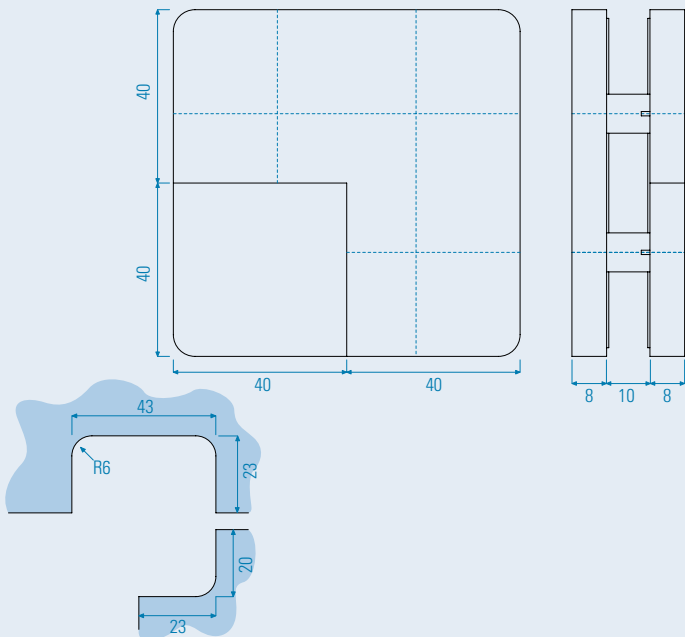

A-62

spojni element steklo-stena desno/levo z omejevalcem za vrata_upper glass-wall door stoppage left + right

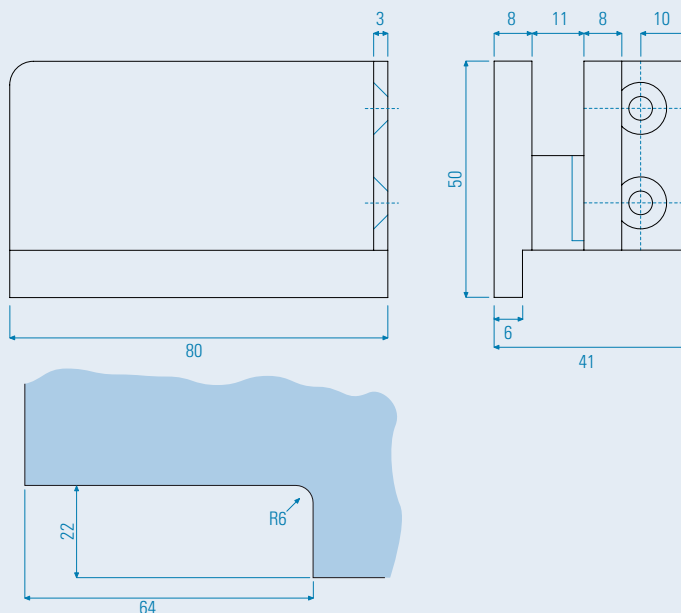
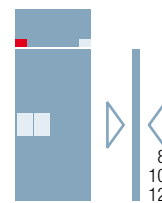

A-73

spojni element steklo-stena_glass-wall vertical clamp

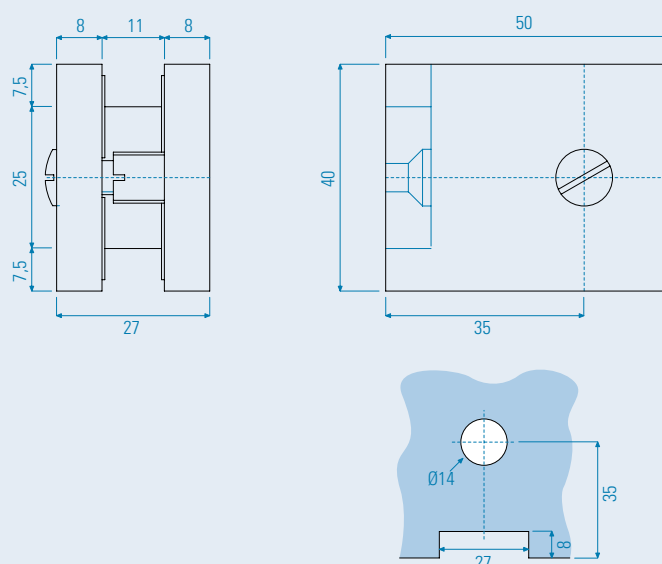
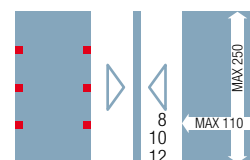

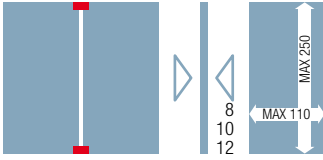

A-74

spojni element za stekleno steno_glass wall joint

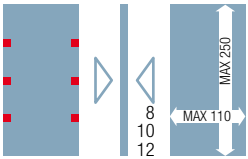
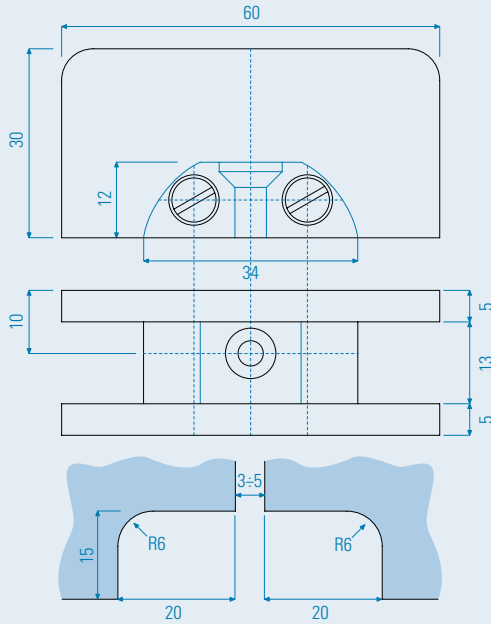

A-78

spojni element za stekleno steno_glass wall joint

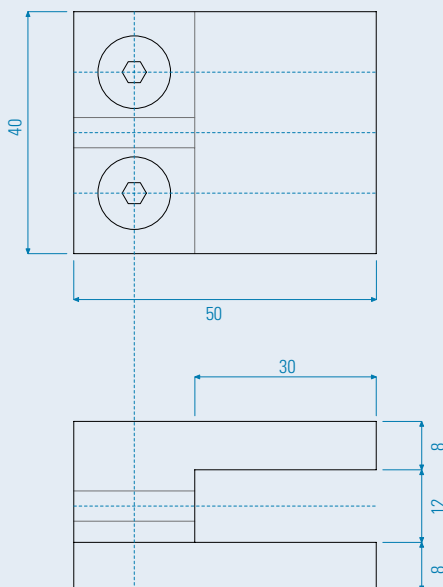

A-110

zapah_bolt

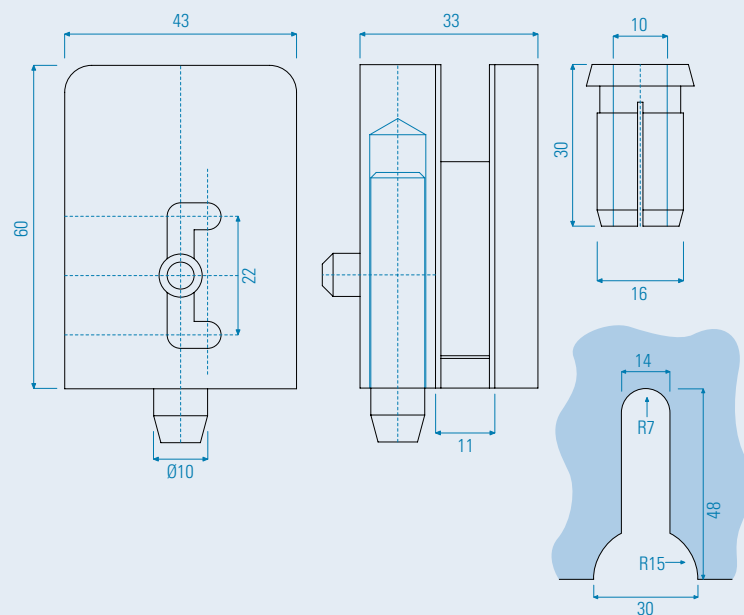
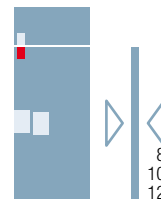

A-111

protizapah_counterbolt

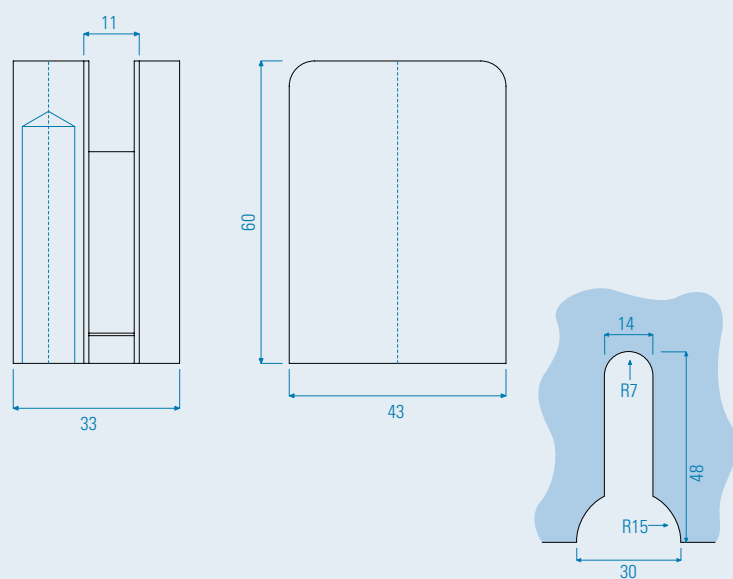
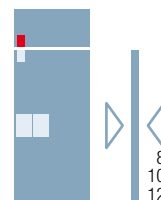

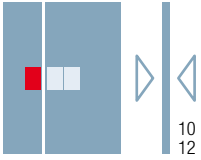

A-131

protiključavnica za steklena vrata_counterlock

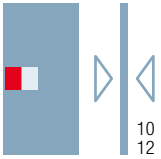
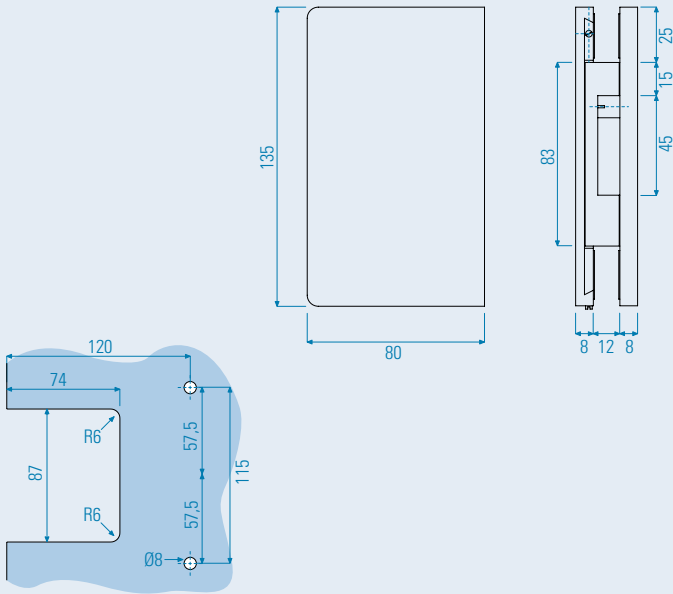

A-132

ključavnica za krilna vrata_lock

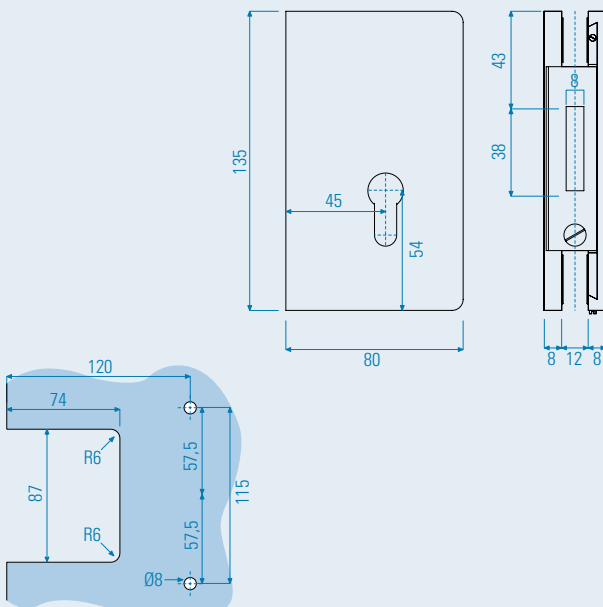

A-131/S

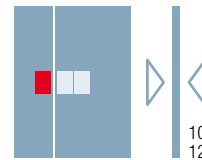

protiključavnica za drsna vrata_sliding door counterlock

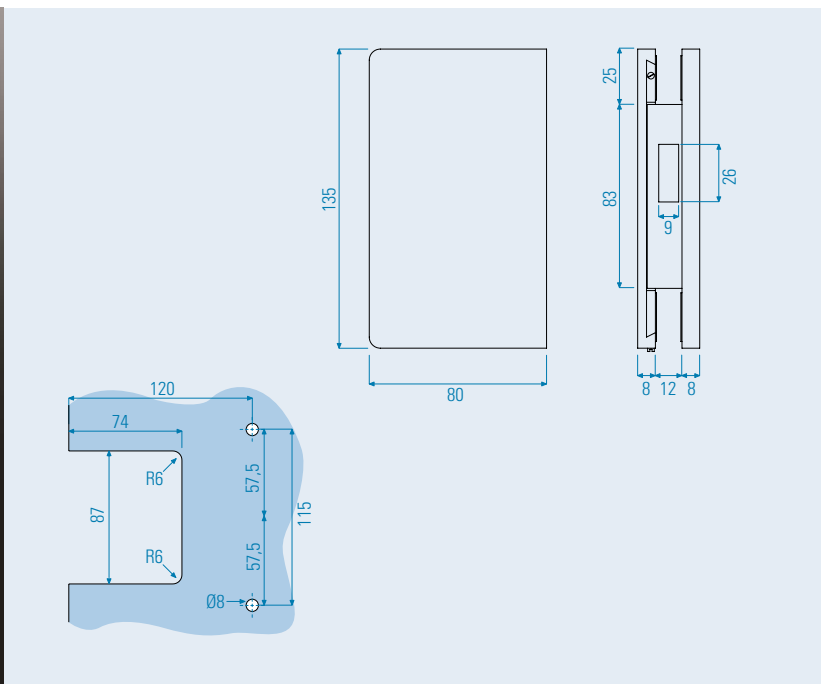

A-132/S

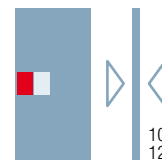

ključavnica za drsna vrata_sliding door lock

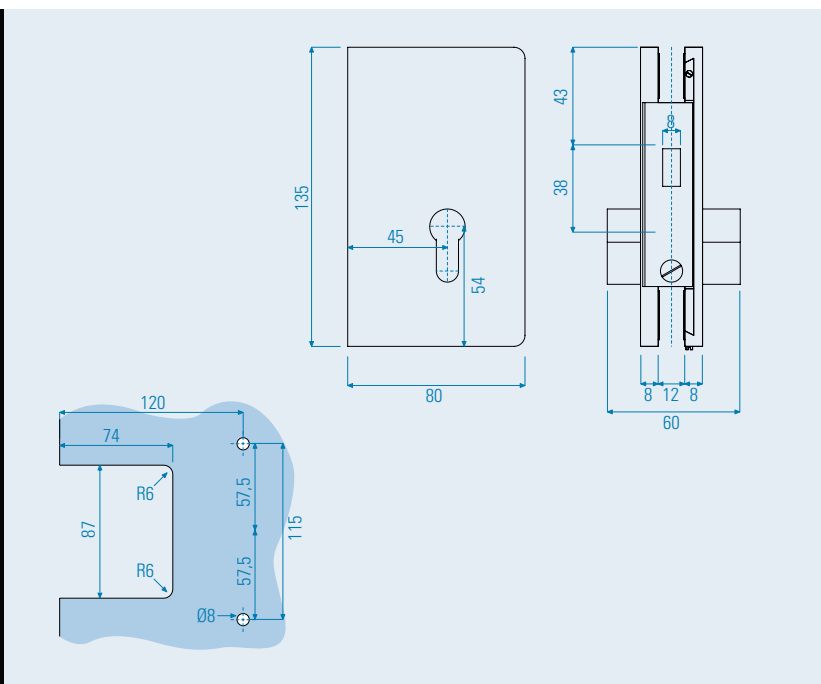

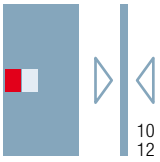

A-135

natična ključavnica s cilindrom_socket lock with cylinder

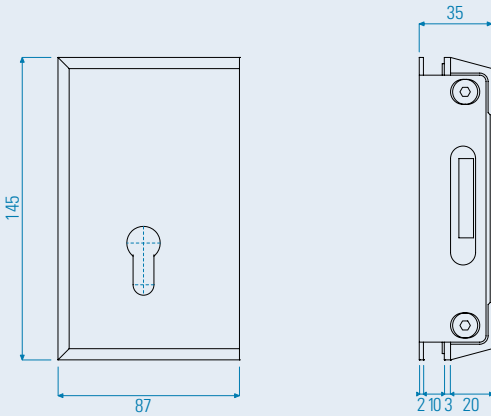

priložen cilindar 30-10
cylinder 30-10 included

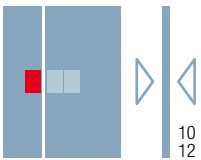

A-136

natična protiključavnica_socket counterlock

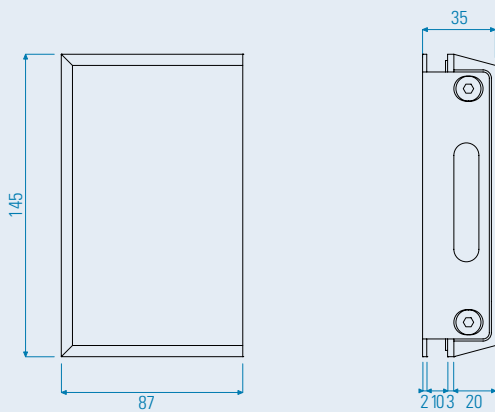

A-140

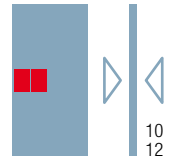

kljuka + ključavnica_handle + lock

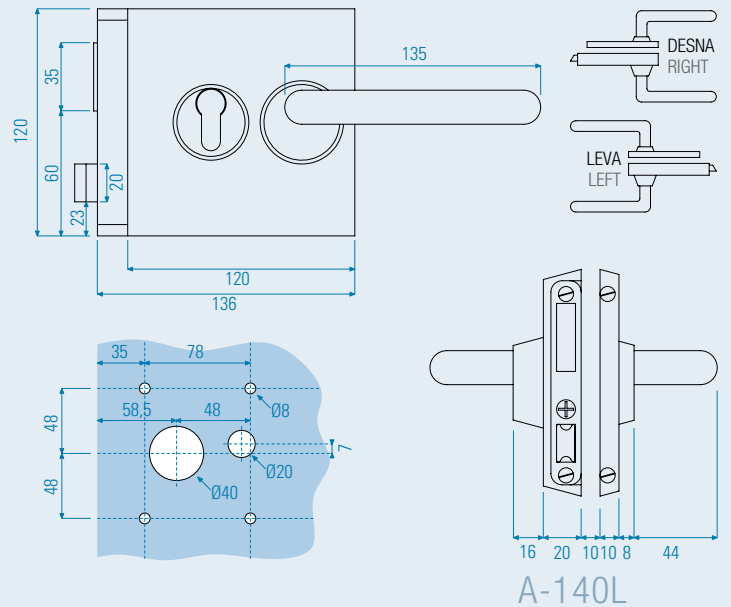

A-140D BD

ročaj + desna ključavnica_handle + right lock

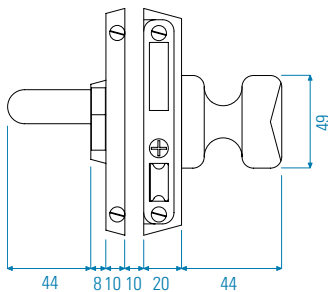

- ročaj - desni okrogel ročaj
- za vrata s pripiro
- handle - right doorknob
- for door with stoppage

A-140D BL

ročaj + desna ključavnica_handle + right lock

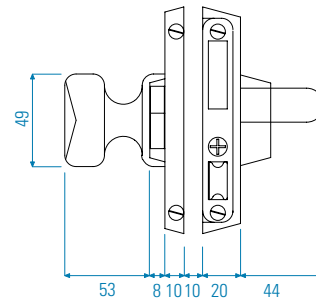

- ročaj - levi okrogel ročaj
- za vrata s pripiro
- handle - left doorknob
- for door with stoppage

A-140L BD

ročaj + leva ključavnica_handle + left lock

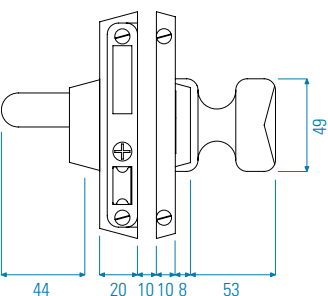

- ročaj - desni okrogel ročaj
- za vrata s pripiro
- handle - right doorknob
- for door with stoppage

A-140L BL

ročaj + leva ključavnica_ + left lock

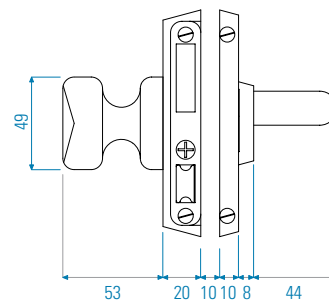

- ročaj - levi okrogel ročaj
- za vrata s pripiro
- handle - left doorknob
- for door with stoppage

A140 BB okrogel ročaj + okrogel ročaj_doorknob + doorknob

ATTENTION!the lock is reversible
la serratura è reversibile

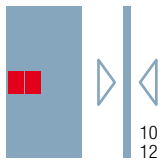

A-141

kljuka + ključavnica_handle + lock

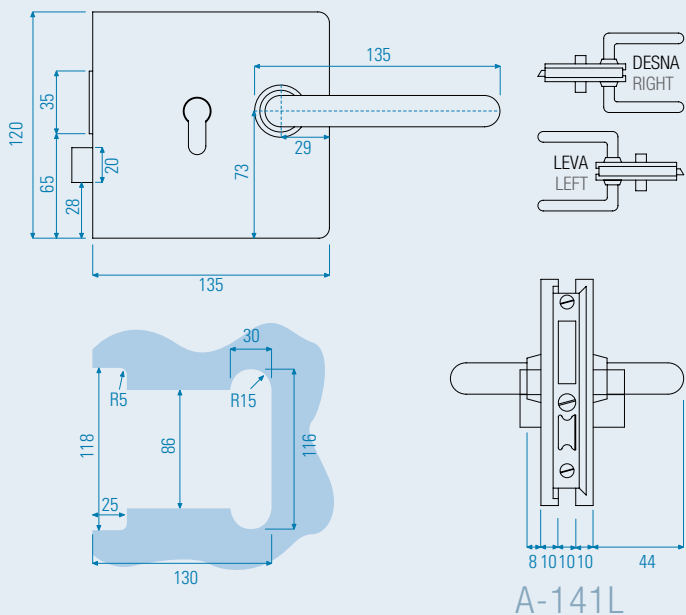

A-141L



obračljiva_reversible

A-141 BD

ročaj - desni okrogel ročaj_handle - right doorknob

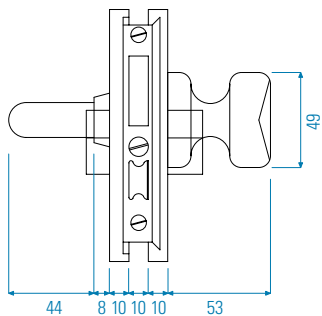

A-141 BL

ročaj - levi okrogel ročaj_handle - left doorknob

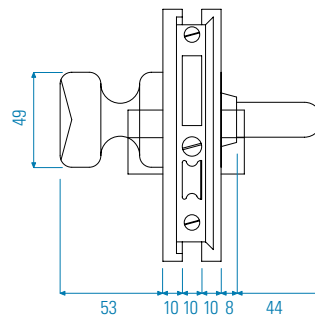

A141 BB okrogel ročaj + okrogel ročaj_doorknob + doorknob

ATTENTION!

the lock is reversible

- pull out and turn 180° the bottom piece

la serratura è reversibile

- estrarre e girare la linguetta inferiore



A-160

zgornji/spodnji tečaj_upper/bottom hinge

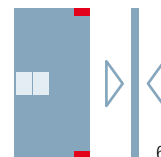

6

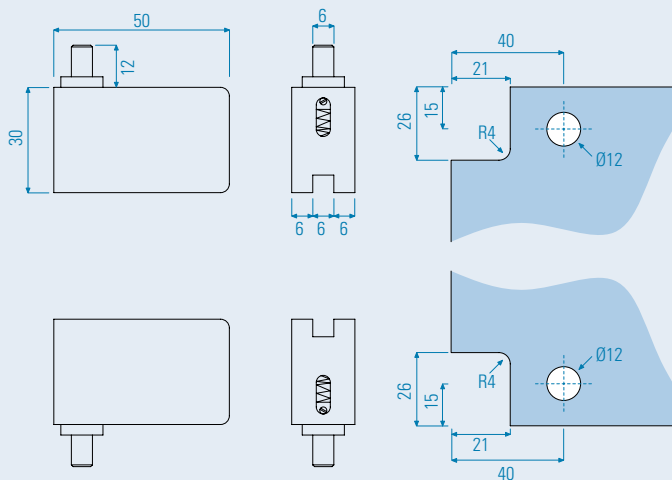

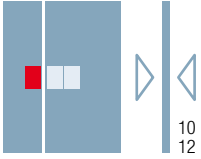

A-142

protiključavnica za A140_A140 counterlock

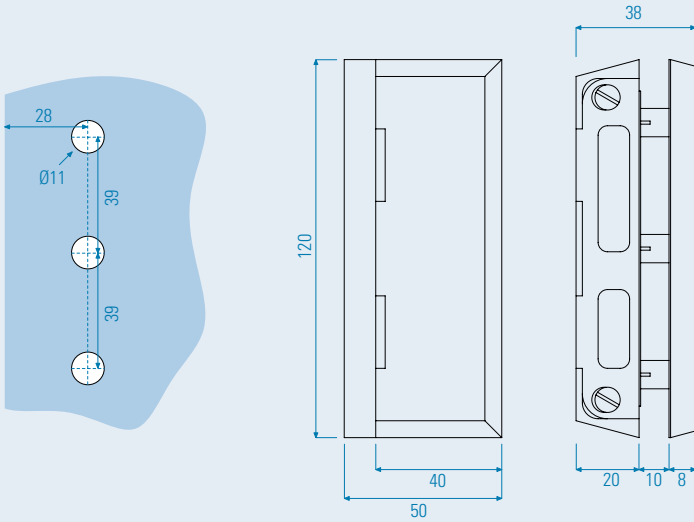

obračljiva_reversible

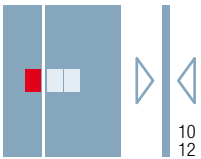

A-143

protiključavnica za A141_A141 counterlock

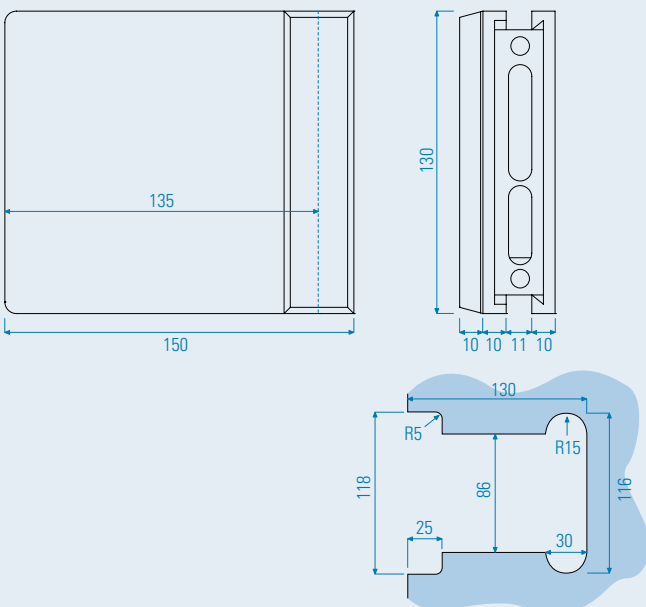

obračljiva_reversible

A-144

ploščica iz nerjavečega jekla_stainless steel lock protection

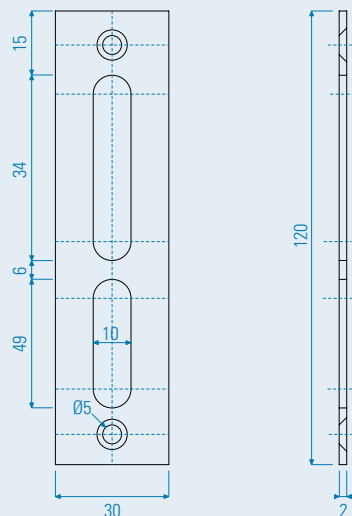
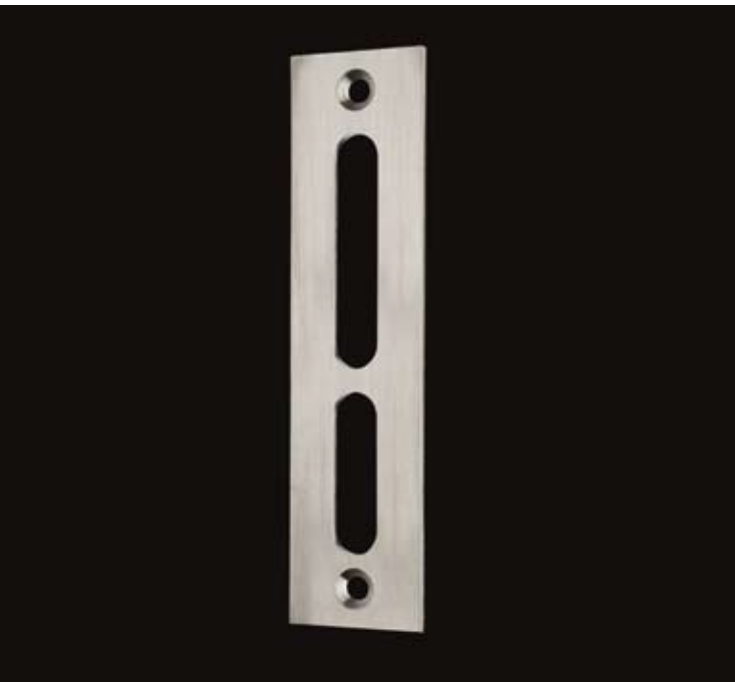

A-153

protiključavnica za A140_A140 counterlocklock protection



obračljiva_reversible

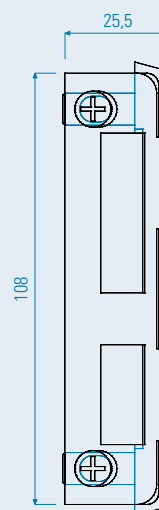

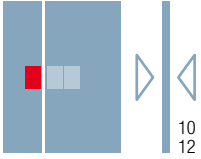

A-154

električna protiključavnica za A141_A141 electric counterlock

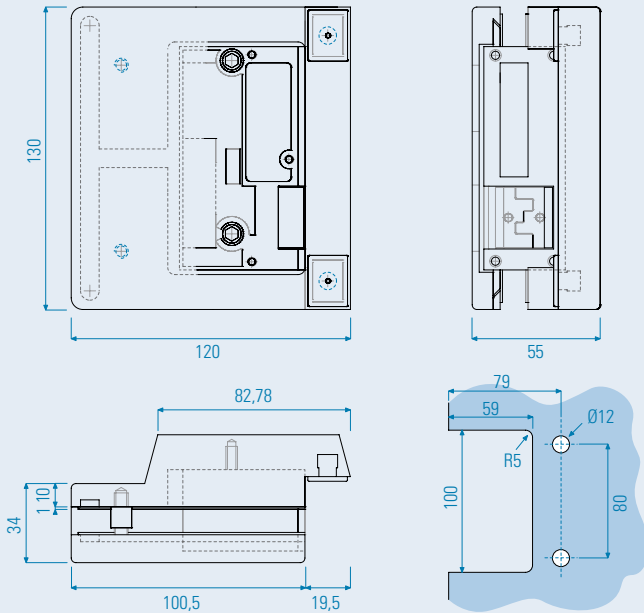

obračljiva_reversible

A-159

protiključavnica_counterlock

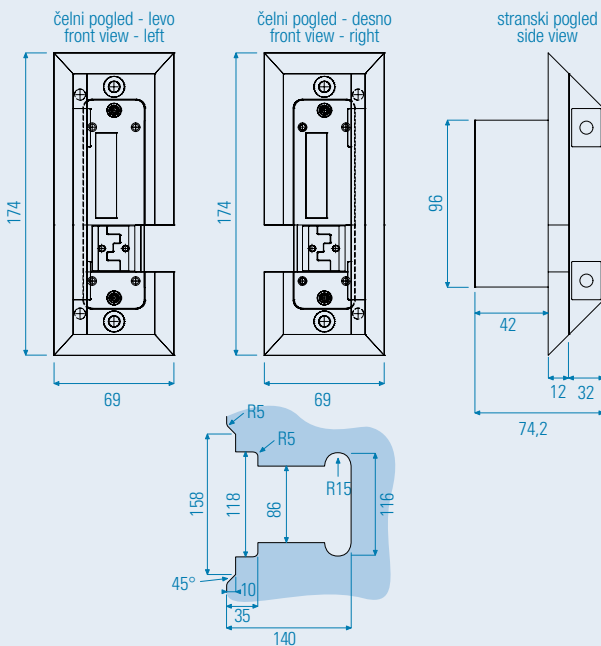

A-180

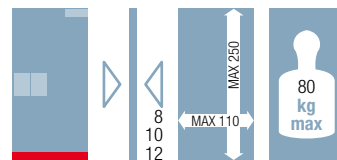

spodnja letev za krilna vrata_wing door bottom slat



s tečajem in zapahom_with hinge and bolt

KODA_CODE	L	L1	L2	
A180/TG/800/L	800	658	606	levo_left
A180/TG/800/R	800	658	606	desno_right
A180/TG/900/L	900	758	706	levo_left
A180/TG/900/R	900	758	706	desno_right
A180/TG/1000/L	1000	858	806	levo_left
A180/TG/1000/R	1000	858	806	desno_right
A180/TG/1200/L	1200	958	906	levo_left
A180/TG/1200/R	1200	958	906	desno_right
A180/TV/800/L	800	658	606	levo_left
A180/TV/800/R	800	658	606	desno_right
A180/TV/900/L	900	758	706	levo_left
A180/TV/900/R	900	758	706	desno_right
A180/TV/1000/L	1000	858	806	levo_left
A180M/TV/1000/R	1000	858	806	desno_right
A180/TV/1200/L	1200	958	906	levo_left
A180/TV/1200/R	1200	958	906	desno_right

TG= Geze pravokotni tečaj (standard)_Geze rectangular hinge (standard)

TI= italijanski kvadratni tečaj_italian square hinge (on demand)

- artikel se vgradi brez izrezov na steklu
- puša P10 ni priložena
- the article can be mounted without glass machining
- inlet piece P10 not included

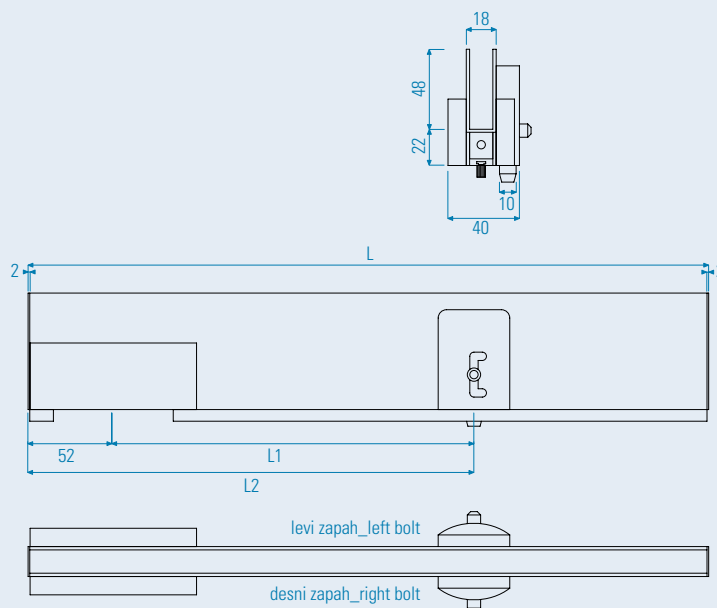

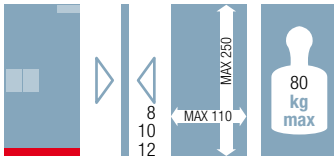

A-181

spodnja letev za krilna vrata_wing door bottom slat



s tečajem in izrezom za cilinder_with hinge and cylinder cutting

- artikel se vgradi brez izrezov na steklu
- the article can be mounted without glass machining

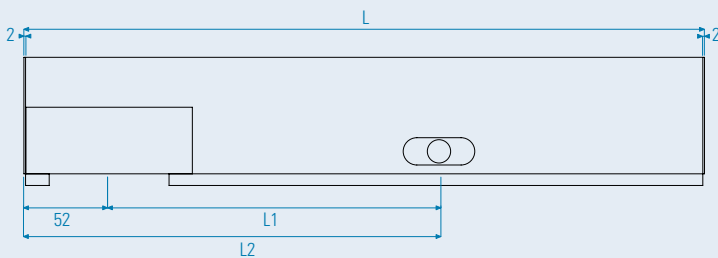
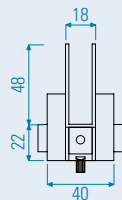

KODA_CODE	L	L1	L2
A181/TG/800	800	658	606
A181/TG/900	900	758	706
A181/TG/1000	1000	858	806
A181/TG/1200	1200	958	906
A181/TV/800	800	658	606
A181/TV/900	900	758	706
A181/TV/1000	1000	858	806
A181/TV/1200	1200	958	906

TG= Geze pravokotni tečaj (standard)_Geze rectangular hinge (standard)

TI= italijanski kvadratni tečaj_italian square hinge (on demand)

A-182/SP

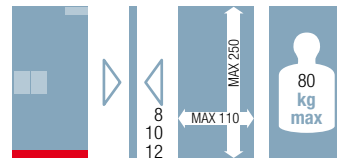

spodnja letev s tečajem za krilna vrata_bottom slat with winged door hinge



CODICE_CODE	L
A182/TG/800	800
A182/TG/900	900
A182/TG/1000	1000
A182/TG/1200	1200
A182/TV/800	800
A182/TV/900	900
A182/TV/1000	1000
A182/TV/1200	1200

TG= Geze pravokotni tečaj (standard)_Geze rectangular hinge (standard)

TI= italijanski kvadratni tečaj_italian square hinge (on demand)

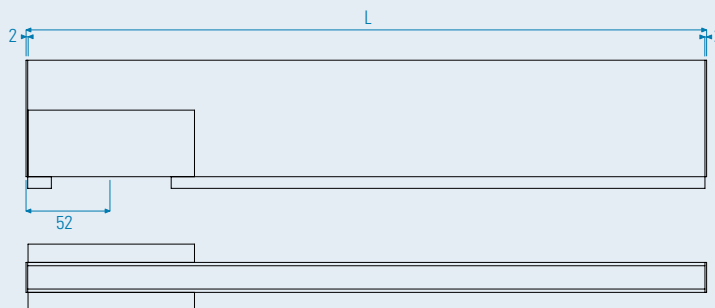
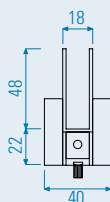

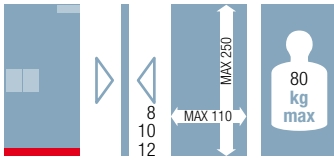

A-182/ZG

zgornja letev s tečajem za krilna vrata_upper slat with winged door hinge

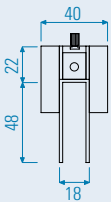

KODA_CODE	L
A182/TZ/800	800
A182/TZ/900	900
A182/TZ/1000	1000
A182/TZ/1200	1200

TZ= zgornji tečaj_upper hinge

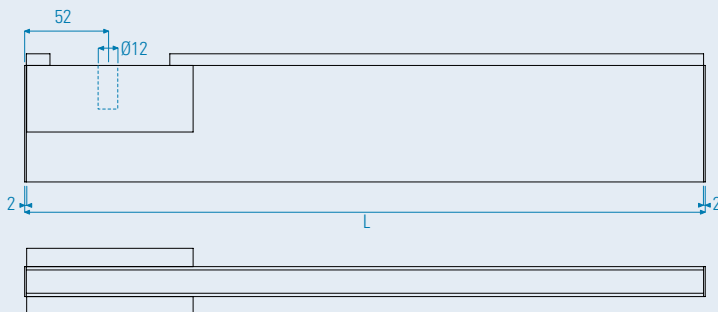

uporablja se z artikli A-47, A-43, A-42 •
used with articles A-47, A-43, A-42 •

A-187

spodnja letev za drsna vrata_sliding door bottom slat

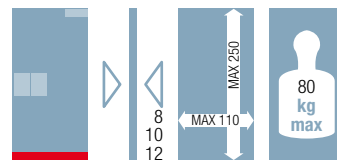

KODA_CODE

A-187L talna letev smučna leva_sliding door bottom slat left

A-187D talna letev smučna desna_sliding door bottom slat right

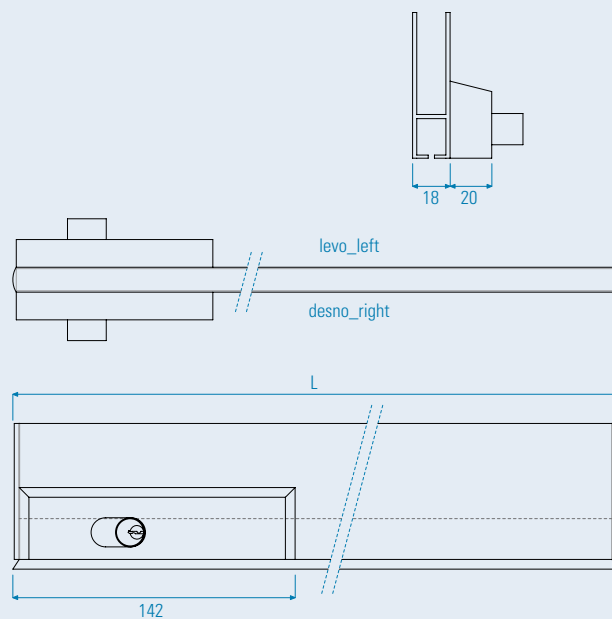

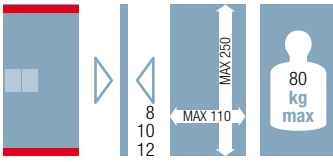

A-182

letev za krilna steklena vrata_glass door slat

A-188

končnik krilne letve za A-182
A-182 slat-ending

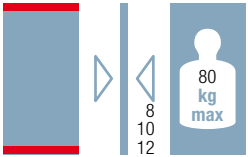
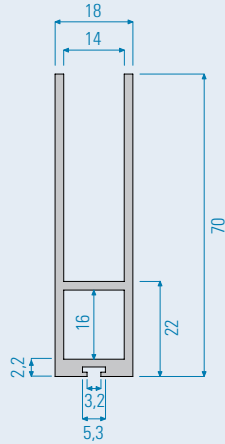

A-183

letev za fiksne steklene stene_fixed glass wall slat

A-186

končnik fiksne letve za A-183
A-183 slat-ending

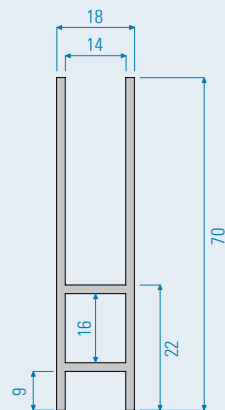

A-190

ravna ploščica_lock protection

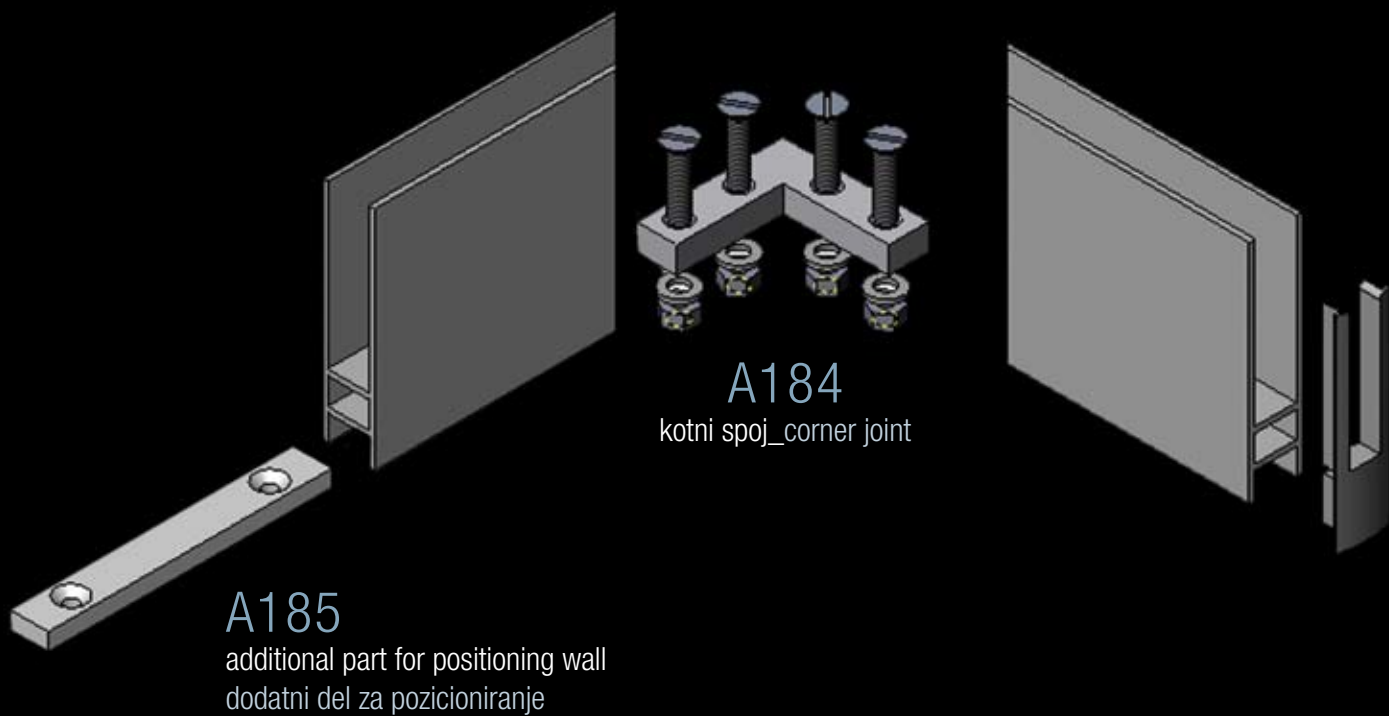
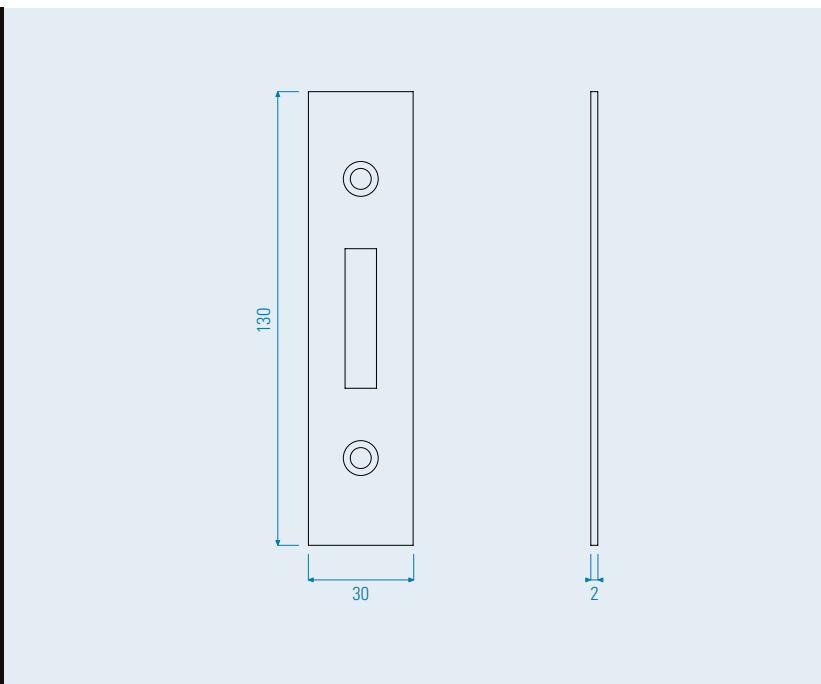

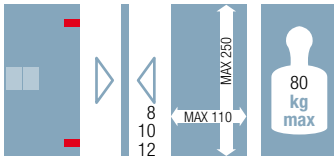

A-222

tečaj steklenih vrat stenski - s posebnim vijakom _glass door wall hinge - with special screw

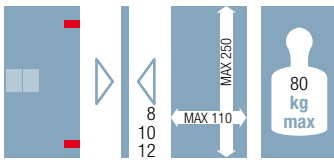
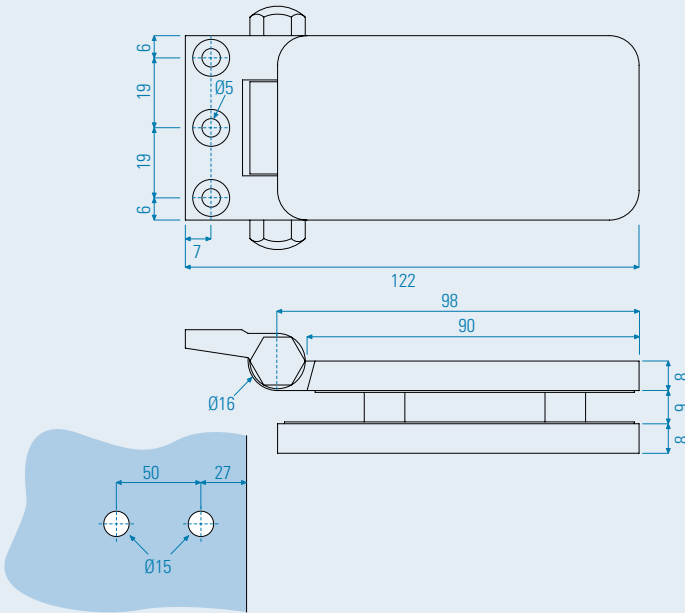

A-223

tečaj steklenih vrat stenski s posebnim vijakom za vrata s pripiro _glass door wall hinge with special screw for doorstep

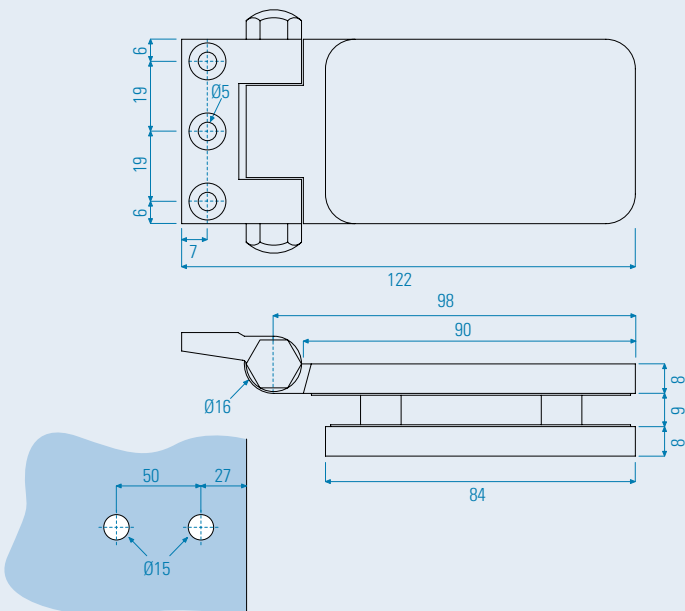

drsni sistemi

sliding systems



vodilo 80 kg
80 kg guide

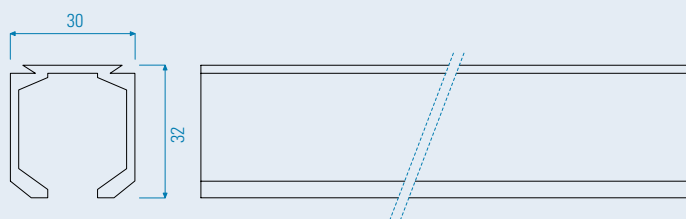

A604M05

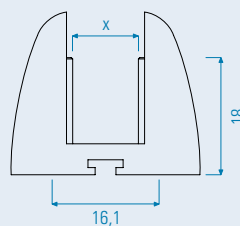
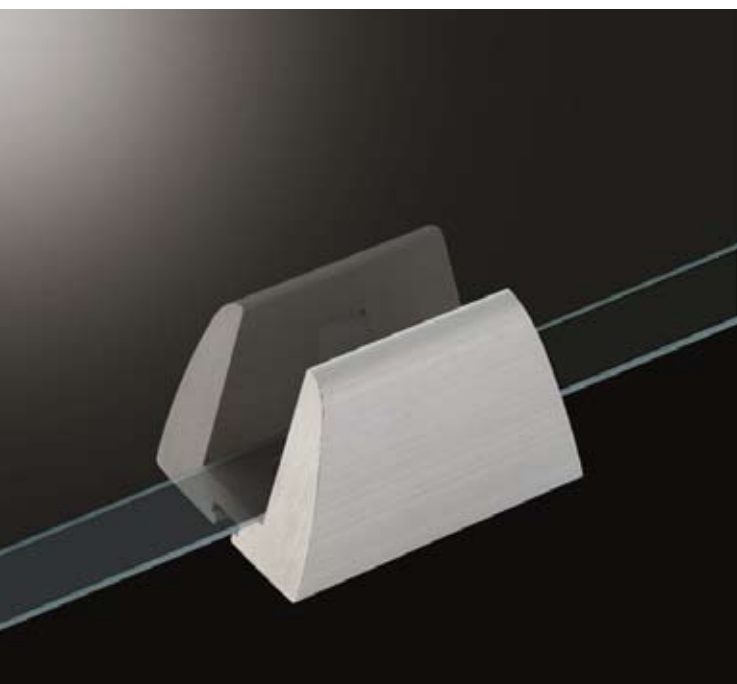

KODA_CODE	X
A604M05/8	8
A604M05/10	10

X = debelina stekla_glass thickness

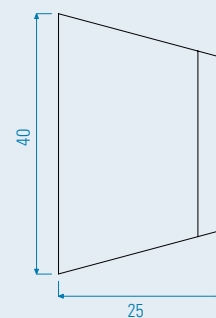
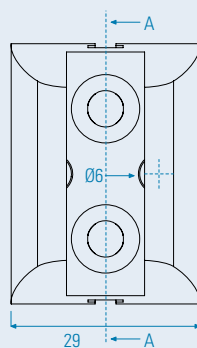

A605M05

garnitura vodila in komplet okovja za stekleno krilo_guide suite and mounting set for glass wing

KODA_CODE	B	L	X
A605M05/1200	510-700	1200	300
A605M05/1500	710-900	1500	450
A605M05/1900	910-1100	1900	600
A605M05/2300	1110-1300	2300	800
A605M05/2800	1310-1500	2800	1100
A605M05/3300	1510-1700	3300	1400

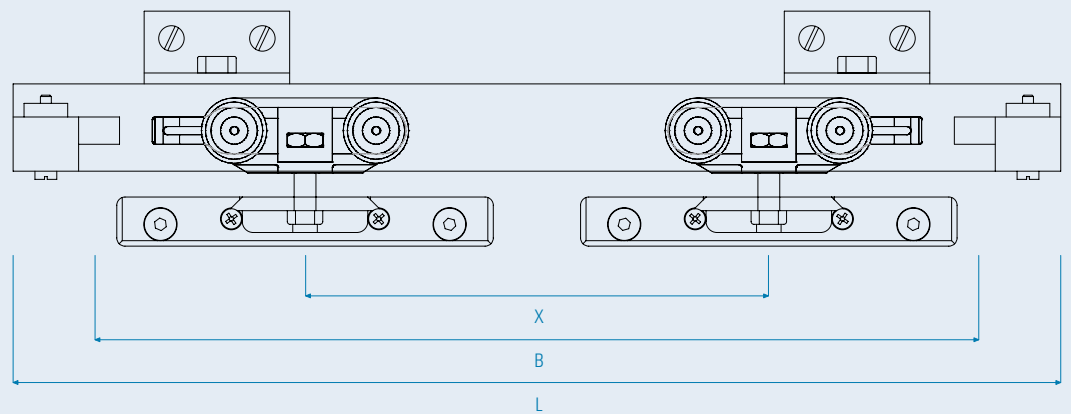
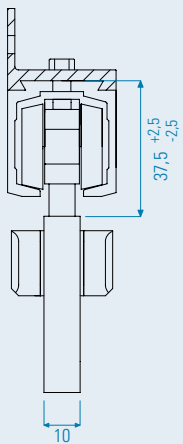
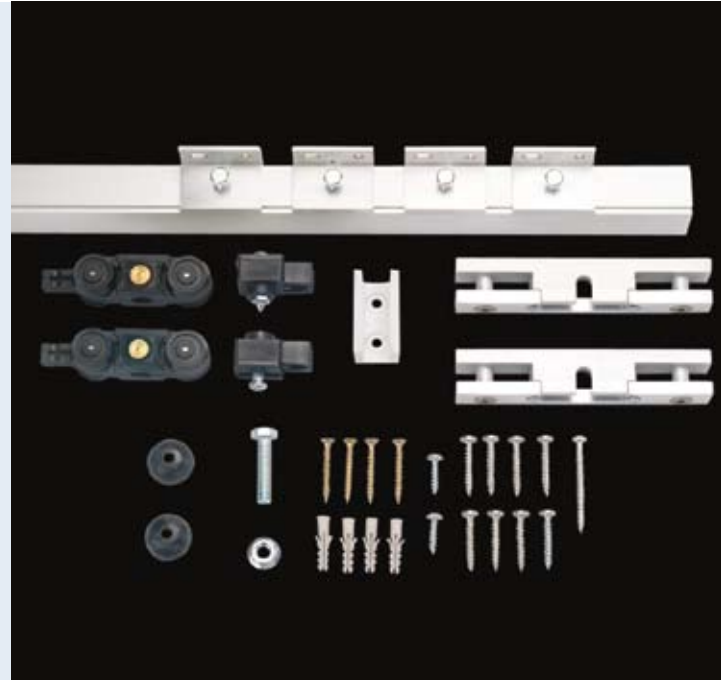

A607M05

garnitura vodila in komplet okovja za leseno krilo_guide suite and mounting set for wooden wing



KODA_CODE	B	L	X
A607M05/1200	510-700	1200	300
A607M05/1500	710-900	1500	450
A607M05/1900	910-1100	1900	600
A607M05/2300	1110-1300	2300	800
A607M05/2800	1310-1500	2800	1100
A607M05/3300	1510-1700	3300	1400

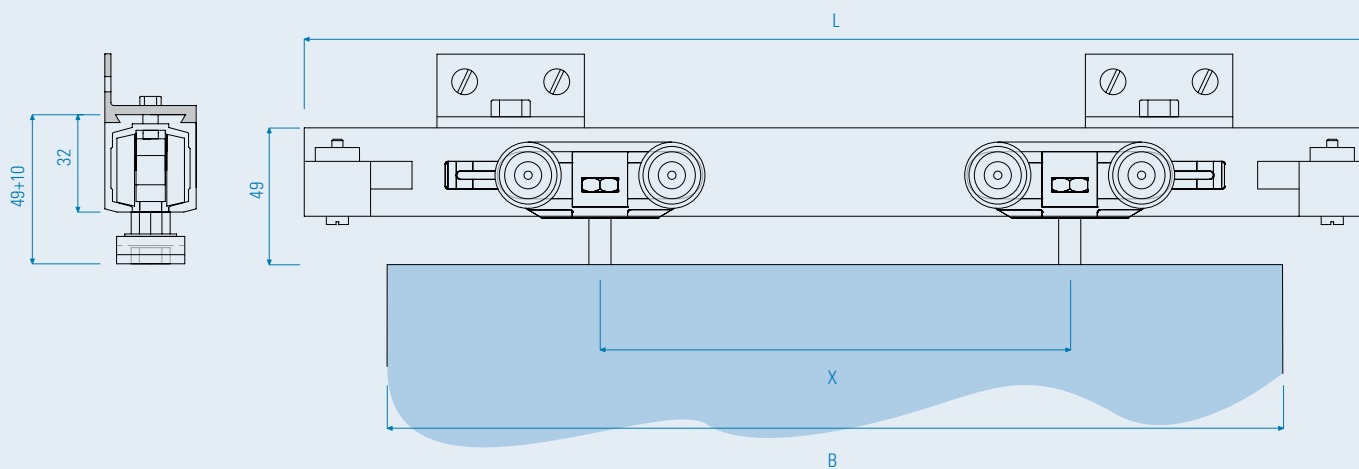

A601M05

2 držali za steklo_2 glass clamps

THE LOWEST KNOWN GLASS-CLAMP ON MARKET
THE LOWEST KNOWN GLASS-CLAMP ON MARKET

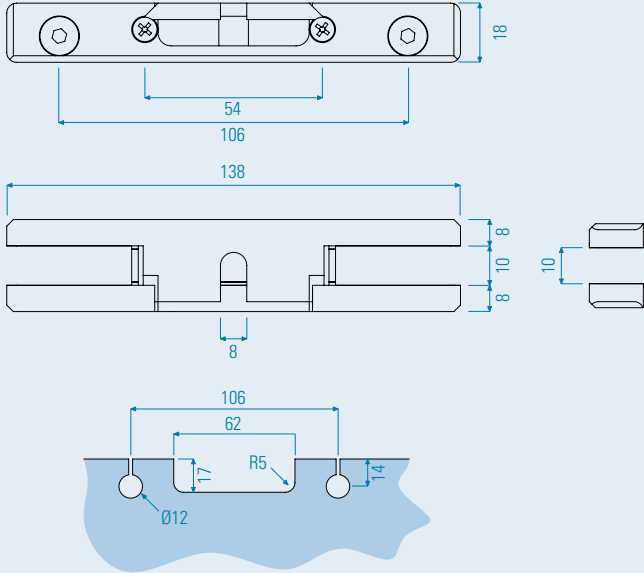

A609M05

2 držali za steklo_2 glass clamps

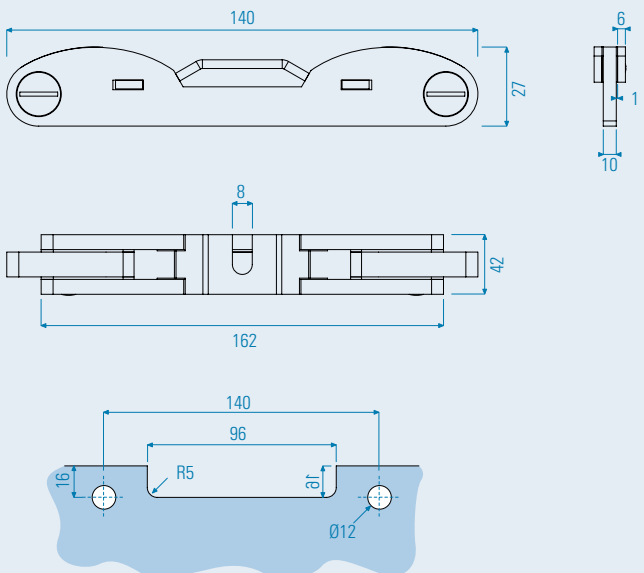

vodilo 140 kg Perlan

140 kg guide Perlan

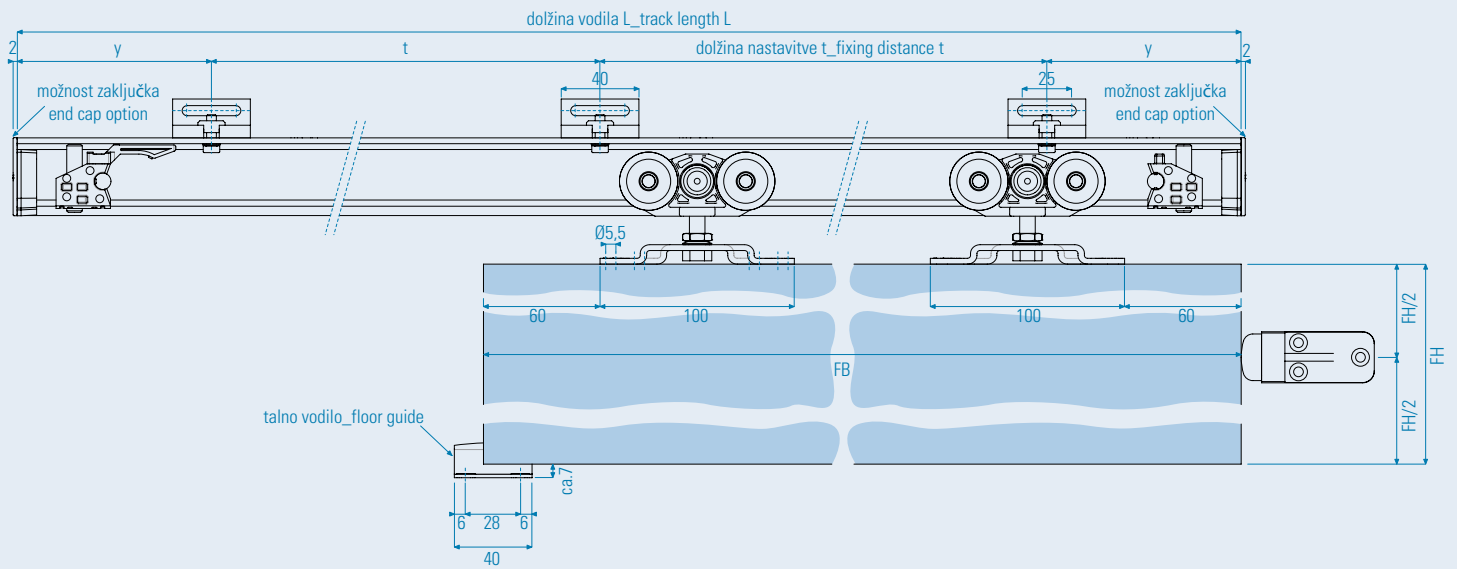
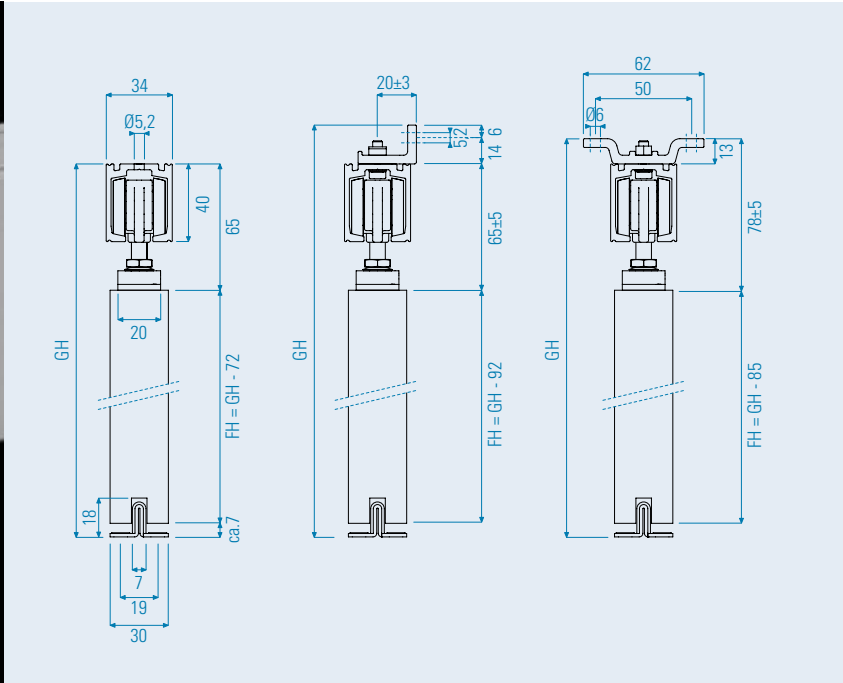

komplet okovja in garnitura vodila 140 kg Perlan

mountings and 140 kg guide Perlan

FB	L	t	x	y
GP 510-700	1250	350	4	100
GP 710-900	1650	350	5	125
GP 910-1100	2050	350	6	150
GP 1110-1300	2450	350	7	175
GP 1310-1500	2850	350	9	25
GP 1510-1700	3250	350	10	50
osnovna dolžina_stock length	6000	350	18	25
posebna dolžina_special length	po naročilu to order	350	-	-

x = število stenskih spon, stropnih spon
number of wall mounting brackets, ceiling mounting brackets

y = razdalja od konca vodila do fiksnega položaja spone
distance from the end of the track to the mounting bracket fixing position



maska_clips cover

montaža na stropu
ceiling mounting

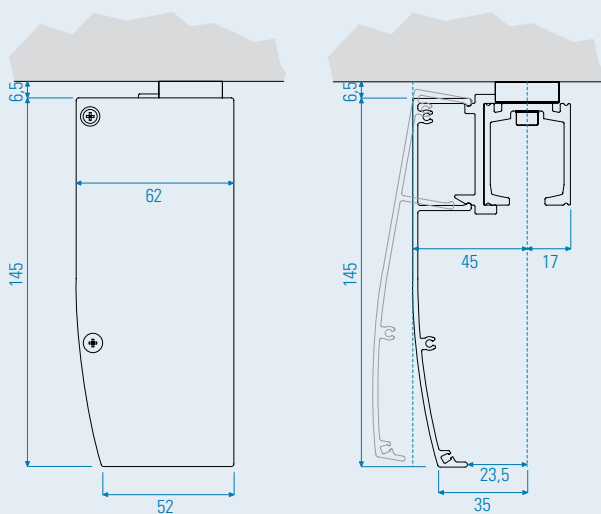

montaža na steni
wall mounting

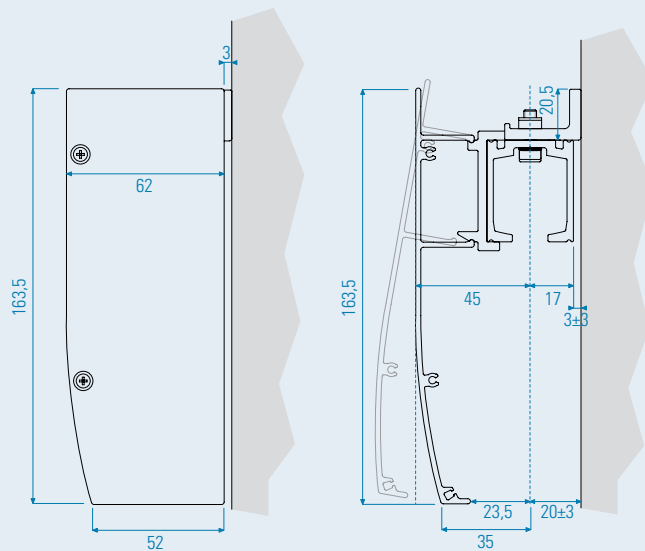

A606M05

aluminijasti okvir za vratno krilo aluminium frame for door wing



- primerno za debelino stekla 6mm
- suitable for 6mm glass thickness

KODA_CODE	Lsp	Hsp	L	H
A606M05/6202000	620	2000	620	2000
A606M05/7202000	720	2000	720	2000
A606M05/8202000	820	2000	820	2000
A606M05/9202000	920	2000	920	2000
A606M05/10202000	1020	2000	1020	2000
A606M05/6202100	620	2100	620	2100
A606M05/7202100	720	2100	720	2100
A606M05/8202100	820	2100	820	2100
A606M05/9202100	920	2100	920	2100
A606M05/10202100	1020	2100	1020	2100

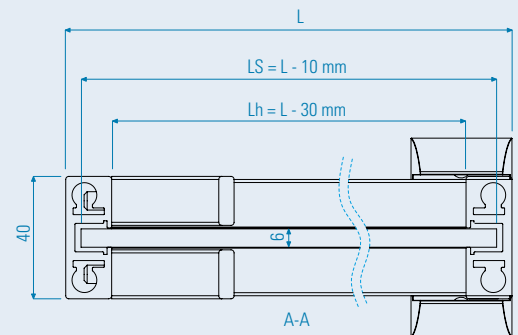
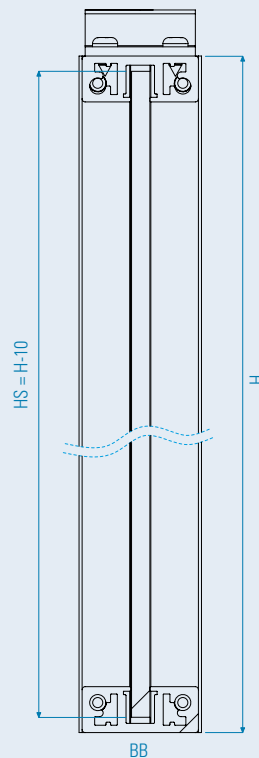
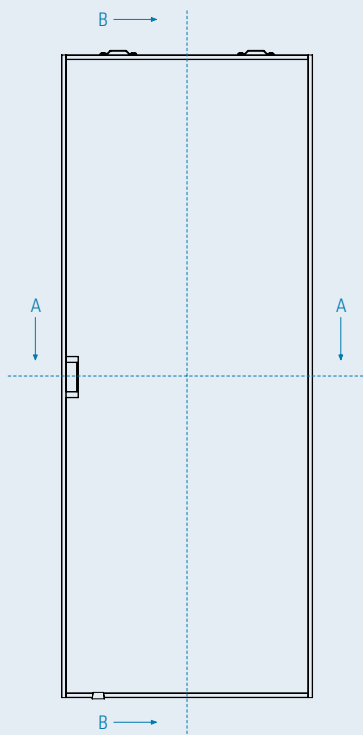



A602M05

par ročajev za okvir vrat _pair of handles for door fram

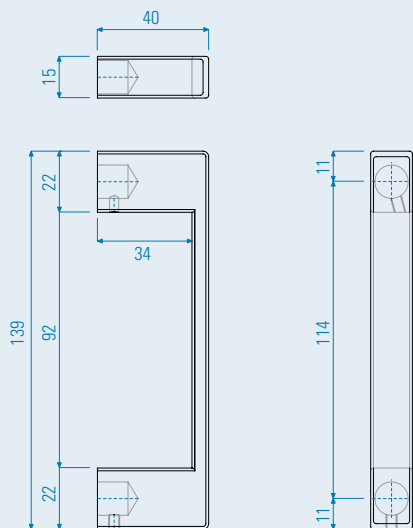

A603M05

talno vodilo za leseno vratno _floor guide rail

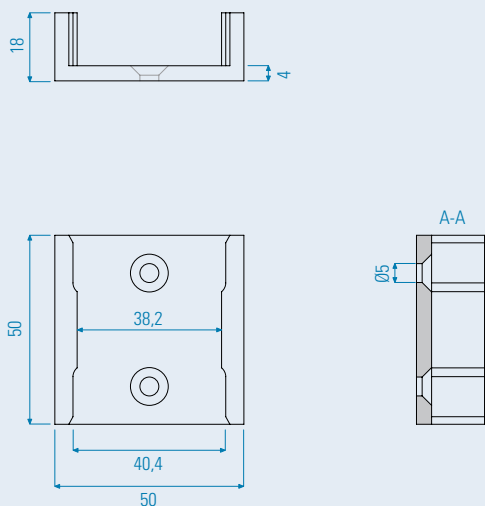

krilo oz. za stekleno krilo z ALU okvirom A606M05
for wooden door wing or glass wing
with ALU frame A606M05



A610M05

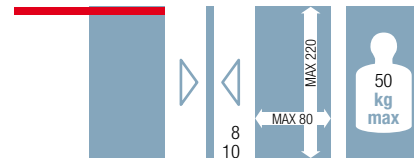

MINI profil za steklena drsna vrata ob steni_MINI profile for glass sliding doors for wall

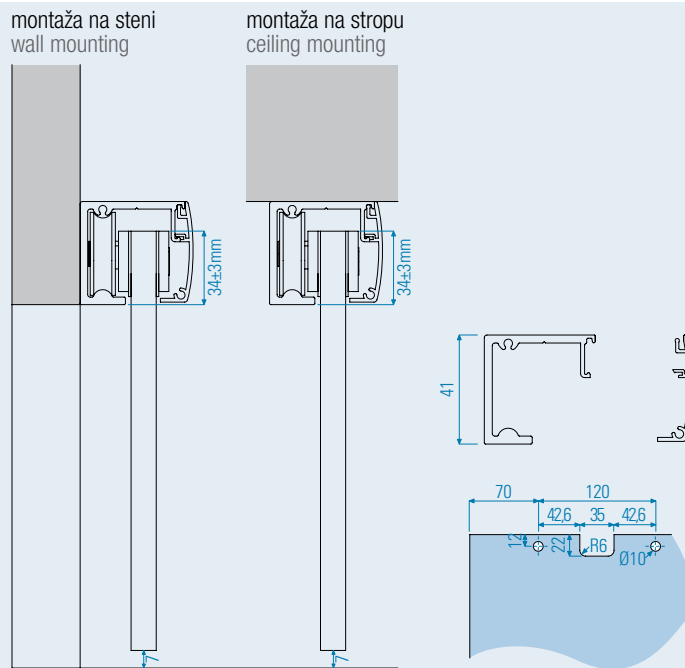

A611M05



NI profil za steklena drsna vrata ob fiksni stekleni steni_MINI profile for glass sliding doors for fixed glass wall

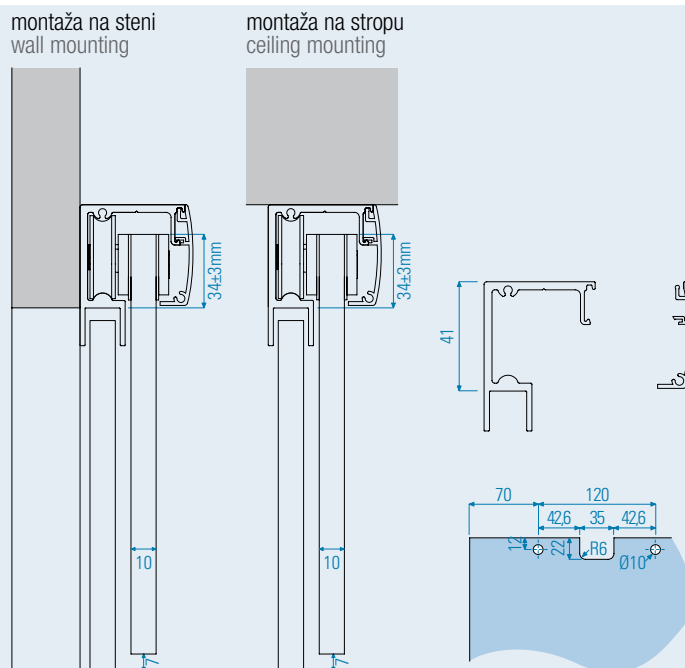

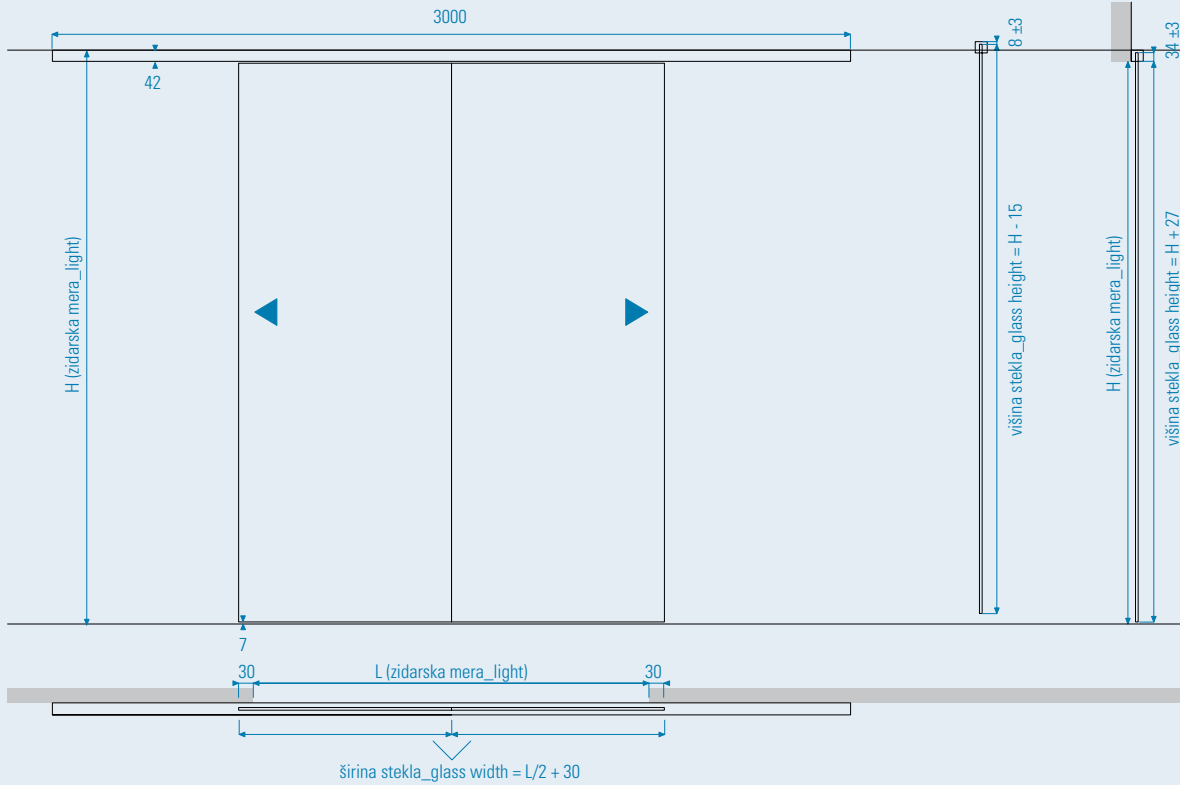
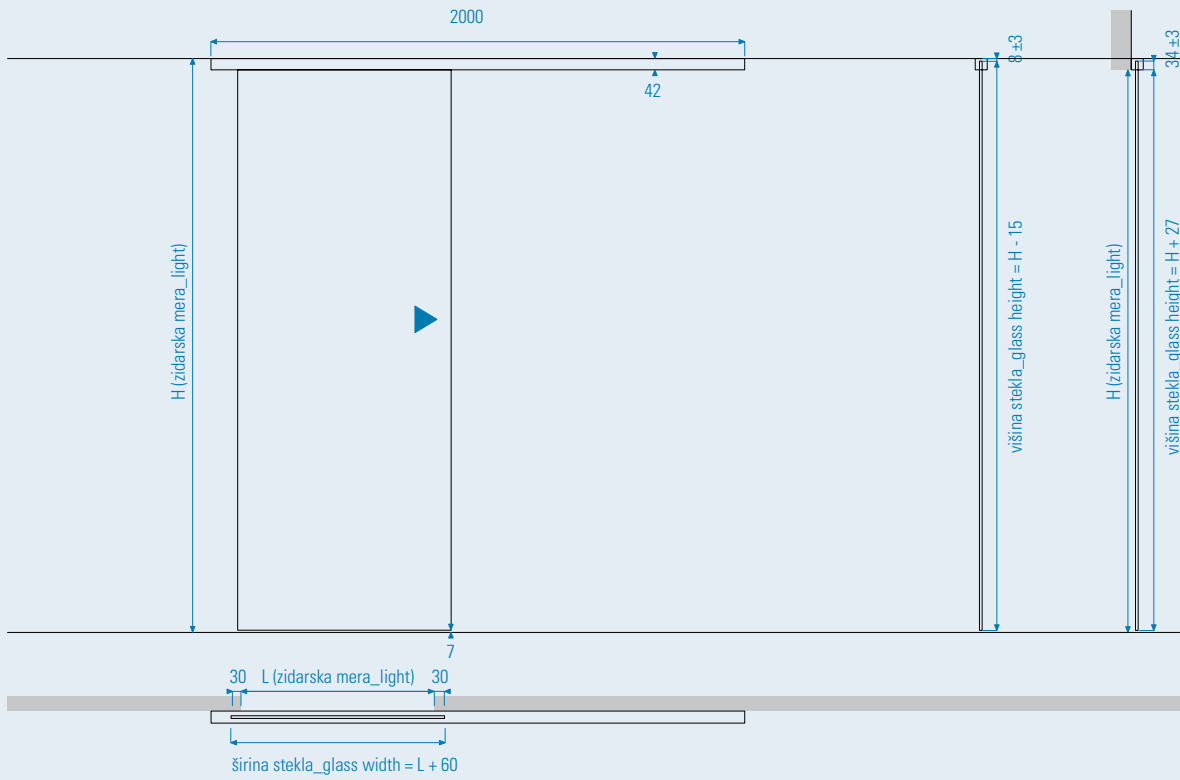

A613M05

VAL drsni sistem steklenega krila ob steno_VAL glass wing sliding system to the wall

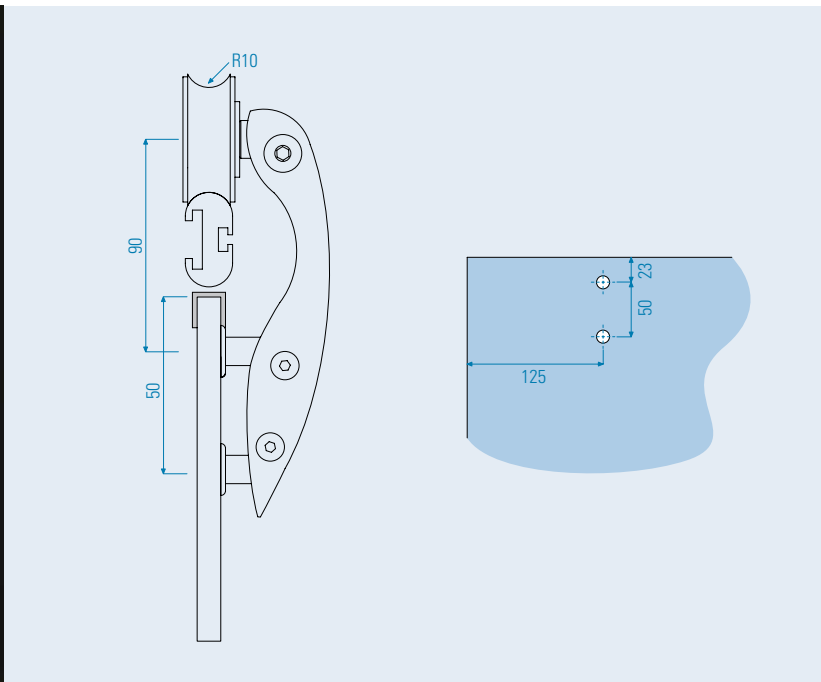

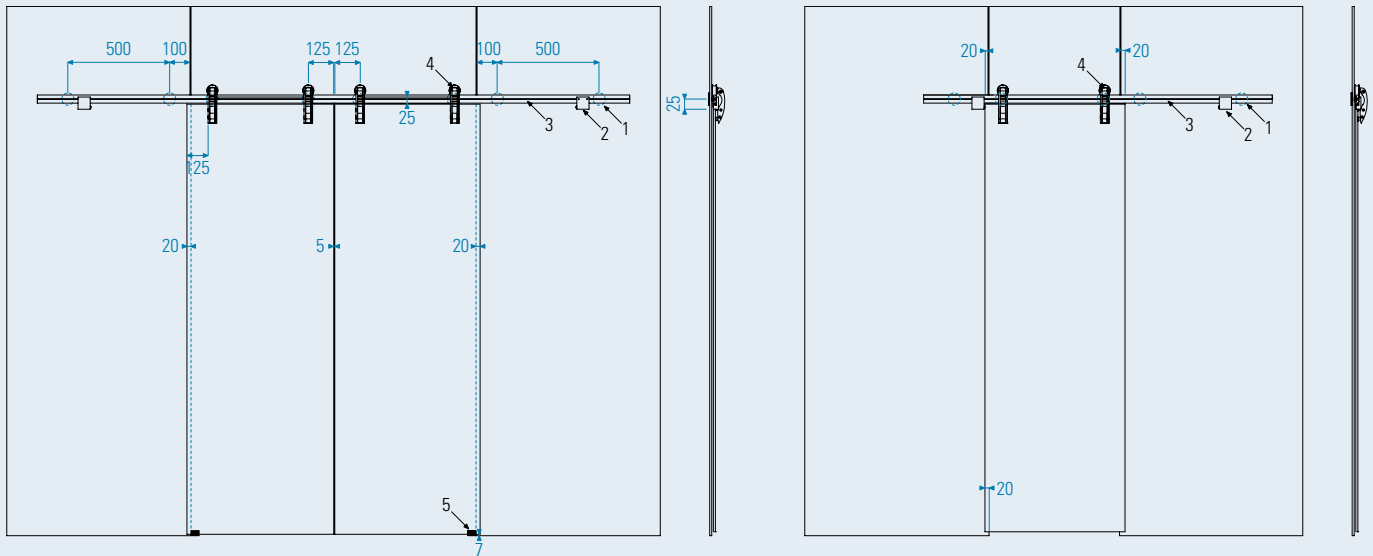

komplet_complete A613M05/3000

opis_description	kosov pieces	koda_code
1 pozicijski zaustavljač_position block	2	A614M05/01
2 pritrditveni element vodila_rail fixer	8	A614M05/02G* A614M05/03W*
3 vodilo_guide rail profile L = 3000 mm	1	A614M05/03
4 tesnilo za drsna vrata_sliding door bracket	4	A614M05/04
5 talna vodila steklenih vrat_glass floor guide	2	A614M05/05
6 varnostni U profil_security U profile	4	A614M05/06

kit A613M05/2000

opis_description	kosov pieces	codice_code
1 pozicijski zaustavljač_position block	2	A614M05/01
2 pritrditveni element vodila_rail fixer	5	A614M05/02G* A614M05/03W*
3 vodilo_guide rail profile L = 3000 mm	1	A614M05/03
4 tesnilo za drsna vrata_sliding door bracket	2	A614M05/04
5 talna vodila steklenih vrat_glass floor guide	1	A614M05/05
6 varnostni U profil_security U profile	2	A614M05/06

kit A613M05/5000

opis_description	kosov pieces	codice_code
1 pozicijski zaustavljač_position block	2	A614M05/01
2 pritrditveni element vodila_rail fixer	8	A614M05/02G* A614M05/03W*
3 vodilo_guide rail profile L = 3000 mm	1	A614M05/03
4 tesnilo za drsna vrata_sliding door bracket	4	A614M05/04
5 talna vodila steklenih vrat_glass floor guide	2	A614M05/05
6 varnostni U profil_security U profile	4	A614M05/06

kit A613M05/3000

opis_description	kosov pieces	codice_code
1 pozicijski zaustavljač_position block	2	A614M05/01
2 pritrditveni element vodila_rail fixer	6	A614M05/02G* A614M05/03W*
3 vodilo_guide rail profile L = 3000 mm	1	A614M05/03
4 tesnilo za drsna vrata_sliding door bracket	4	A614M05/04
5 talna vodila steklenih vrat_glass floor guide	2	A614M05/05
6 varnostni U profil_security U profile	2	A614M05/06

*G = za montažo na steklo_for glass structure

*W = za montažo na steno_for wall structure

A608M05

aluminijasti podboj za vgradno kaseto drsnih vrat_aluminum doorstep for sliding door floorspring cassette



KODA_CODE	Lsp	Hsp	L	H
A608M05/6202000	590	2000	620	2000
A608M05/7202000	690	2000	720	2000
A608M05/8202000	790	2000	820	2000
A608M05/9202000	890	2000	920	2000
A608M05/10002000	990	2000	1020	2000
A608M05/6202100	590	2100	620	2100
A608M05/7202100	690	2100	720	2100
A608M05/8202100	790	2100	820	2100
A608M05/9202100	890	2100	920	2100
A608M05/10202100	990	2100	1020	2100

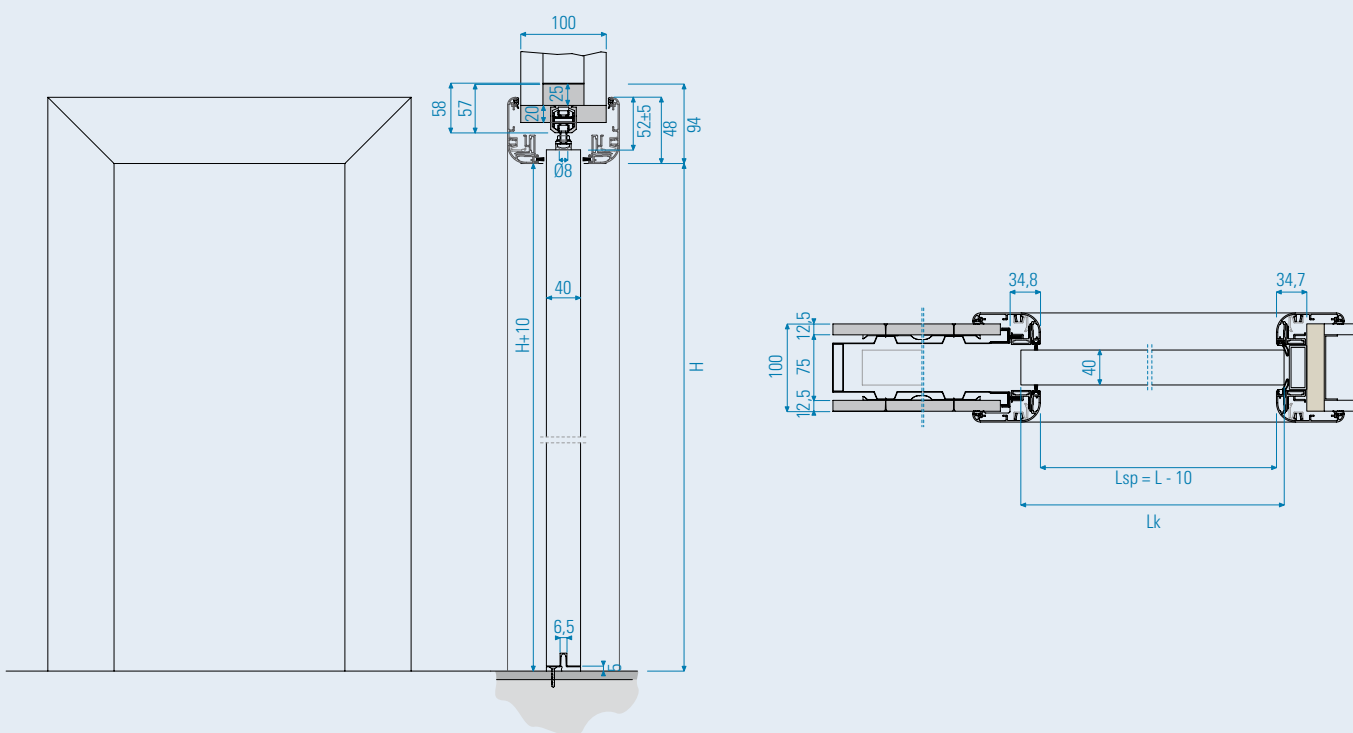



sklopni sistemi

folding doors



A505

spojni tečaj_bottom hinge

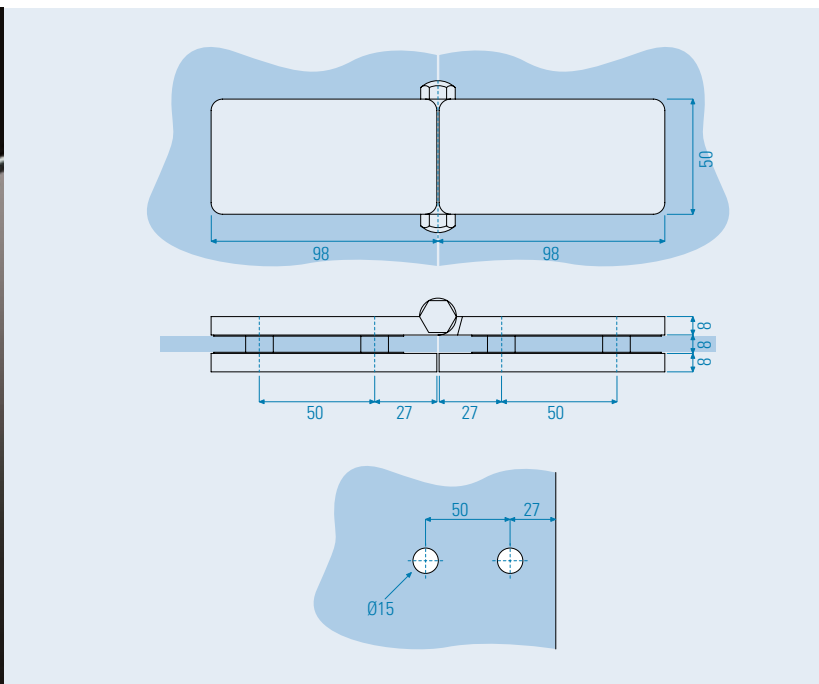

A507

spojni tečaj z vrtljivo glavo_double top hinge with rotating head

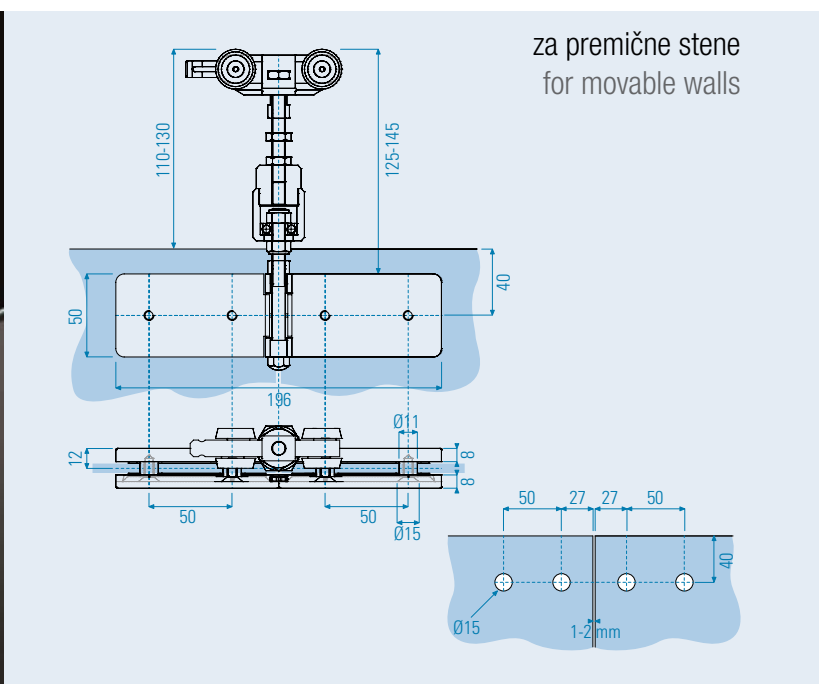

A508

zgornji enojni tečaj z vrtljivo glavo_top hinge with rotating head

per pareti mobili_for movable walls

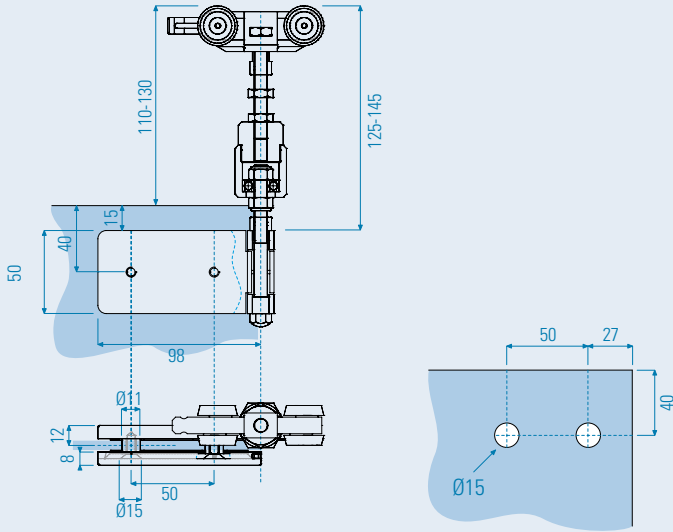

A509

enojni spodnji tečaj z valjčkom_single bottom hinge with roller

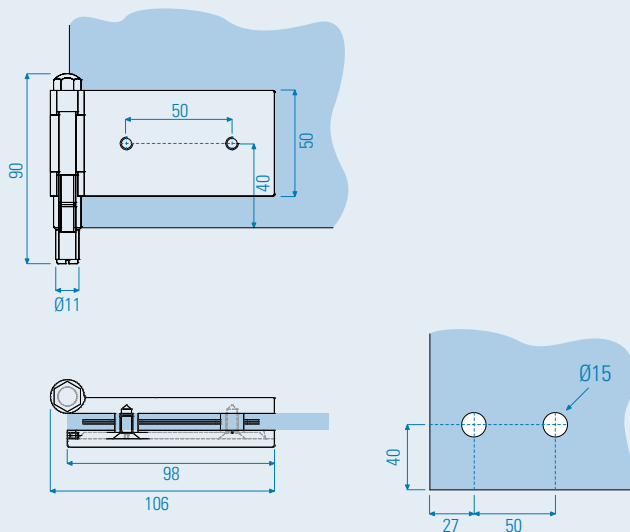

A510

dvojni spojni spodnji tečaj z valjčkom_double bottom hinge with roller



za premične stene
for movable walls

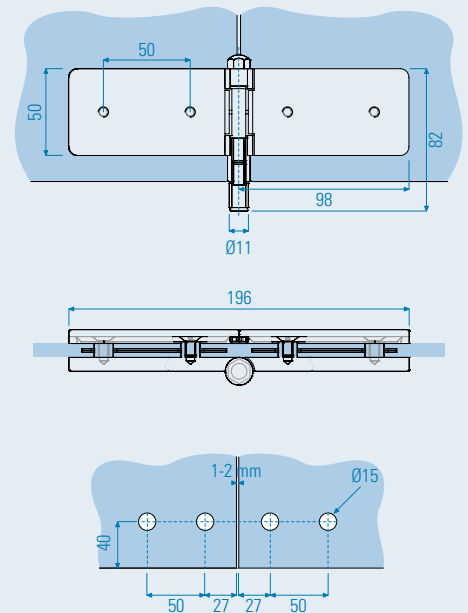

A511

spodnje vodilo_bottom guide profile

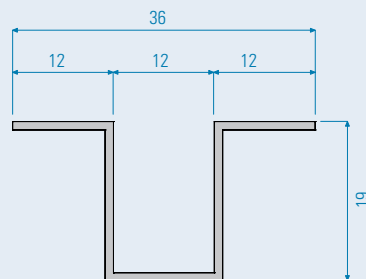

za premične stene
for movable walls

lahko se uporabljajo z vodilom
za 80 kg ali 120 kg
can be used with guide profile
for 80 kg or 120 kg



A512

zgornji tečaj nihalnih vrat v kombinaciji s sklopnimi_swinging door top hinge in combination with joining

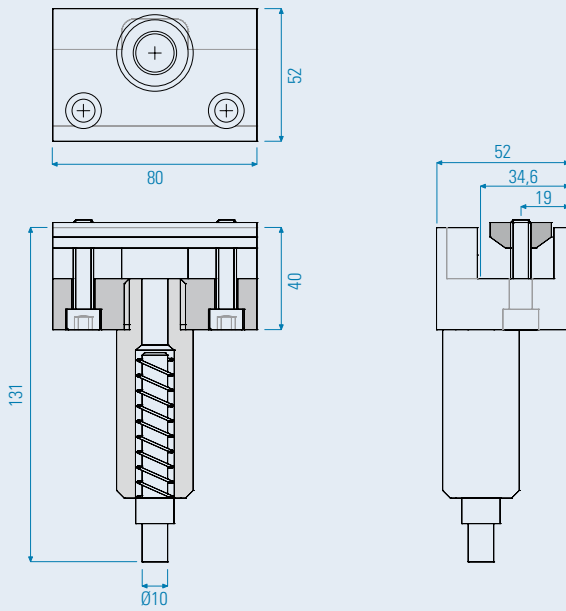

talna zapirala

floorsprings



US120

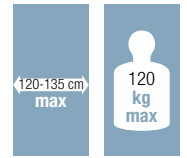

talno zapiralo_floorspring



- 130° odpiranje
- ostane odprto na 90°
- 2 nastavljivi zapiralni hitrosti
- inox prekrivna plošča

- 130° opening
- hold open at 90°
- 2 adjustable closing speeds
- SS cover plate

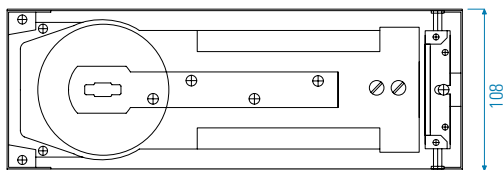
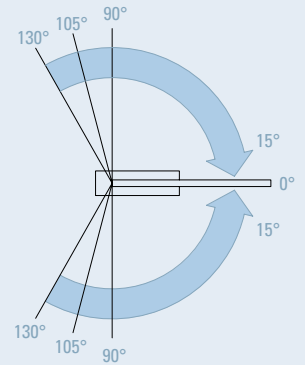
**Vgradna škatla**

Galvanizirana vgradna kasetna se uporablja pri dvignjenih ali plavajočih tleh.

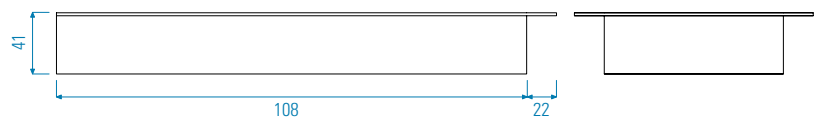
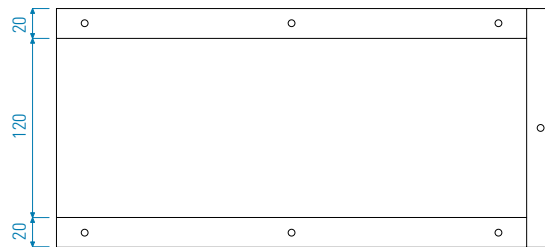
**Floorspring box**

Galvanised floorspring box to be used with raised or suspended floors.

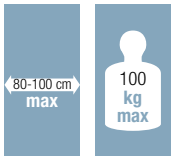

US130

talno zapiralo_floorspring

- 180° odpiranje
- US 130 ostane odprt na 90°
- US 130N brez zaustavljanja na 90°
- 2 nastavljivi zapiralni hitrosti
- inox prekrivna plošča

- 180° opening
- US 130 hold open at 90°
- US 130N without hold open at 90°
- 2 adjustable closing speeds
- SS cover plate

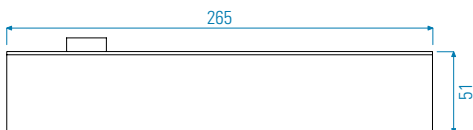
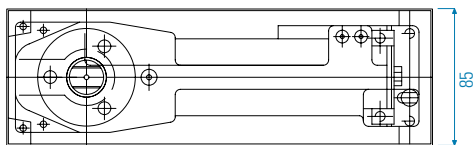
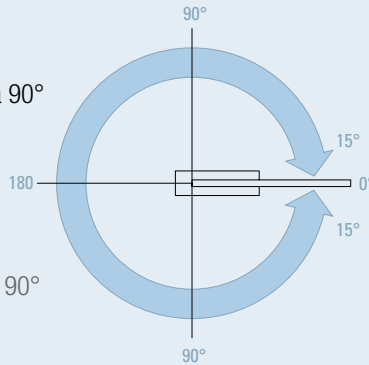

Vgradna škatla

Galvanizirana vgradna kasetna se uporablja pri dvignjenih ali plavajočih tleh.

Floorspring box

Galvanised floorspring box to be used with raised or suspended floors.

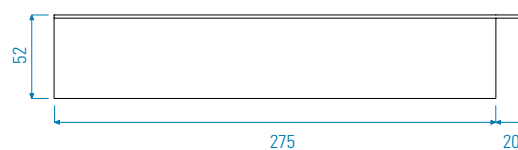
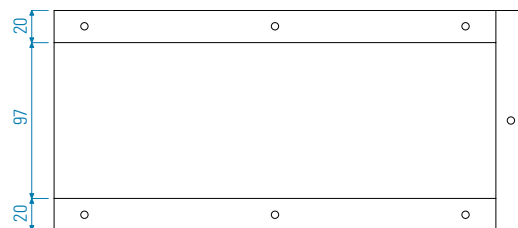

MOLLIS

talno zapiralo_floorspring

120-135 cm
max

120
kg
max



- standardna izvedba z GEZE nastavkom
- DORMA nastavek po naročilu
- GEZE hinge default
- DORMA hinge on request

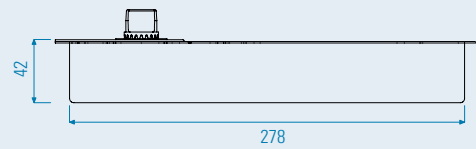
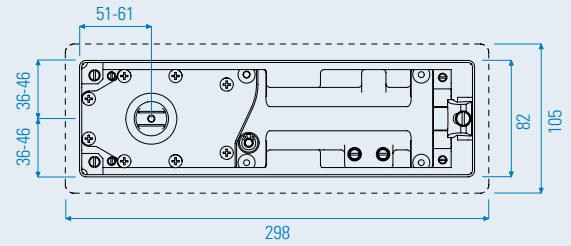

opcije in dodatki

optional

ALUKOMEN

A-47

zgornji del nasadila_upper part of hinge



UT110

zgornji tečaj nihalnih vrat_swinging door top hinge



C3030

profilni cilinder 30-30_profiled cylinder 30-30



talna puša_inlet piece

P08 za fi 8mm_P08 for fi 8mm
 P10 za fi 10mm_P10 for fi 10mm
 P12 za fi 12mm_P12 for fi 12mm



A30

tečajna medeninasta ploščica_hinge brass plate

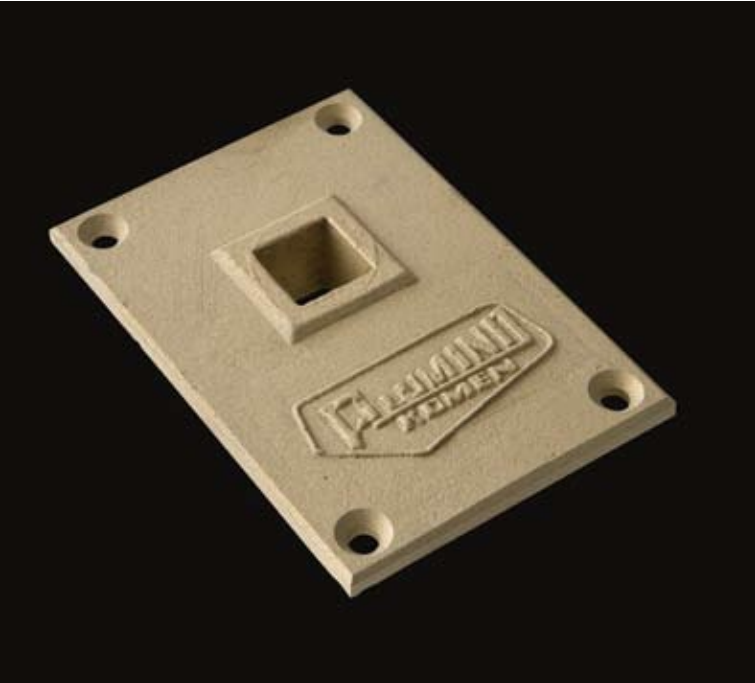

A31A

reducirni vložek_reductive inlet piece



A31D dorma

reducirni vložek za Dorma tečaj
reductive inlet piece for Dorma hinge



A32

tečajna puša_hinge bush



